



AC Kits, Heater Units & Systems



ON-HIGHWAY

OFF-HIGHWAY

CONSTRUCTION

RAIL

BOOM TRUCK

FORKLIFT



<https://atc.ca>
800-295-4156

1416 Graham's Lane
Burlington, Ontario
Canada, L7S 1W3



www.hammondac.com
800-267-2665

125 Samnah Crescent
Ingersoll, Ontario, N5C 3J7



VISIONAIRE, INC.

www.visionaire-inc.com
866-838-2810

1401 Valley View Lane #135
Irving, TX 75061

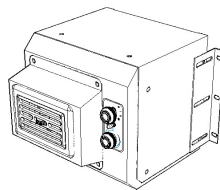

A/C, Heater Units & Systems

Fast Finder

Condensers.....	2 - 25
Rooftop	2-4, 6, 10-17
Back Wall.....	3-12
Skirt Mount	7-9
Wall Mount.....	16, 17, 19, 25
Rooftop Behind Cab	18
Floor Mount	18
Foot Mount	20
Universal.....	21-24
Evaporators.....	26-49
Rooftop	26, 27
Back Wall.....	27-33, 35
Under Dash	34
Ductable	34
Headliner	36, 37
Floor Mount	39, 44, 45
Wall Mount.....	38, 47-49
Ceiling Mount.....	40-42
External Wall Mount	43, 46
Between the Seat	45
Heaters	50-56
Ductable	51, 53
Under Dash	51, 53, 55, 56
Self Contained Units	57-67
Back Wall.....	57-59, 62, 65
Rooftop	58, 60, 61, 63, 66, 67
Ductable	59, 62, 64, 65
HEPA Cab Pressurizer.....	68-69
External/Internal	68, 69
Hydraulic Direct Drive Compressors.....	70

part#	pg	part#	pg
43-3000..	2	890152-12/24VDC - AC & Heat.....	37
43-3010.....	3	(RH connection)	
43-3025.....	4	890121-12/24 VDC.....	38
43-3030.....	5	890119-12/24 VDC.....	39
43-3060.....	6	520-12VDC-SALON	40
43-3081.....	7	520-24VDC-SALON	40
43-3040.....	8	HA-9750-12	41
43-3045.....	9	HA-9750-24	41
43-3085.....	10	411-580-E35PL-12	42
43-3110.....	11	411-580-E35PL-24	42
43-3130.....	12	520-NGC-100	43
891029-12VDC.....	13	HA-320-7-12	44
891005-12/24VDC-AC.....	14	411-300-T30	45
891024-12V	15	901-12	46
891008-12/24VDC.....	16	901-24	46
891027-12/24VDC.....	17	901-000-A-100.....	47
HA-100-12-HD.....	18	520-12VDC-210SP	48
HA-100-24-HD.....	18	520-12VDC-210DC	49
HA-100-12-HD-VERT	19	42-2200	50
HA-100-24-HD-VERT	19	42-2205	51
HA-100-3-LRG-12	20	42-2210	52
HA-100-3-LRG.....	20	42-2215	53
420-904-100-12.....	21	42-2900	54
420-904-100-24.....	21	892041-12/24VDC.....	55
420-860-977-12.....	22	892002-12/24VDC.....	56
420-860-977	22	47-7110	57
420-855-NEXG.....	23	47-7060	58
420-855-NEXG-24.....	23	47-7170	59
424-008-H50.....	24	47-7070	60
K TCK COND SPLIT	25	47-7070 BD	61
44-4025	26	47-7100	62
44-4030	27	47-7000	63
44-4050	28	47-7115	64
44-4050M	29	47-7150	65
44-4100	30	47-7055	66
44-4145	31	890050-12/24VDC - AC only.....	67
44-4150	32	890066-12/24VDC - AC & Heat.....	67
44-4161	33	896052ATC	68
44-4220	34	896068ATC	69
890091-12/24VDC - AC & Heat.....	35	41-1200-AC Compressor.....	70
890129-12/24VDC - AC & Heat.....	36	41-1300-AC Compressor.....	70
890151-12/24VDC - AC & Heat.....	37	41-1310-AC Compressor.....	70
(LH connection)		41-1320-AC Compressor.....	70

CONDENSER — ROOFTOP 43-3000

CONSTRUCTION • AGRICULTURE • FORESTRY • UNIVERSAL

The model 3000 Compact Condenser is designed for small cab applications. This forced air condenser can be used with the model 4100 evaporator.

**Not Sure What To Order?
We Can Help . . .**

See the A/C System
Configuration Worksheet
on the last page of this catalog.

<http://www.visionaire-inc.com>
866-838-2810



PART NO.

- 43-3000-1000**12VDC
- 43-3000-2000**24VDC

SHIPPING NOTICE

Due to the size and weight this unit must be shipped LTL.

SPECIFICATIONS

- Capacity.....18,000 BTU/hr
- Current Draw8 amps @ 12VDC4 amps @ 24VDC
- Weight26 LBS
- Condenser CoilCopper Tubing Aluminum Fin
- Dimensions.....20.8" L x 10.1" W x 9.4" H
- Motor9" Condenser Fan

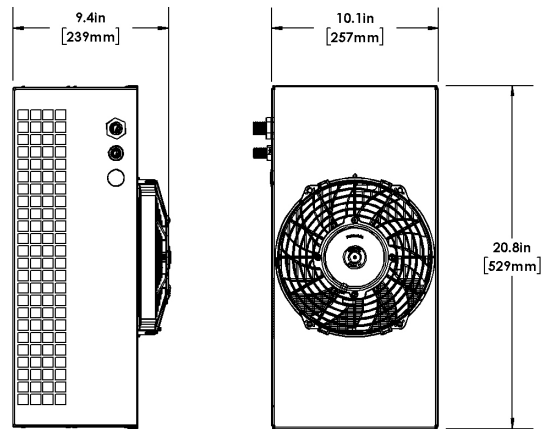

OPTIONS

- Remote Evaporator
- Refrigeration Hose Kit
- Remote Compressor

SERVICE PARTS

Part No.

- 10-10-3000Condenser Coil
- 14-10-0911Condenser Fan

CONDENSER — ROOFTOP — BACK WALL

43-3010

CONSTRUCTION • AGRICULTURE • FORESTRY • UNIVERSAL

Mounted to a vertical or horizontal surface, the model 3010 Condenser is versatile and rugged. Ideal for use with the model 4100, and 4050 Evaporators. The 3010 unit is also available with an externally mounted drier and binary switch.

**Not Sure What To Order?
We Can Help . . .**

**See the A/C System
Configuration Worksheet
on the last page of this catalog.**

<http://www.visionaire-inc.com>
866-838-2810



PART NO.

43-3010-100012VDC
43-3010-200024VDC
43-3010-1000Kw/Drier 12VDC
43-3010-2000Kw/Drier 24VDC

SHIPPING NOTICE

This unit can be shipped by UPS or LTL.

SPECIFICATIONS

Capacity33,000 BTU/hr
 Current Draw11 amps @ 12VDC 5.5 amps @ 24VDC
 Weight36 LBS
 Condenser CoilCopper Tubing Aluminum Fin
 Dimensions20.4" L x 14.5" W x 10.2" H
 Motor14" Condenser Fan

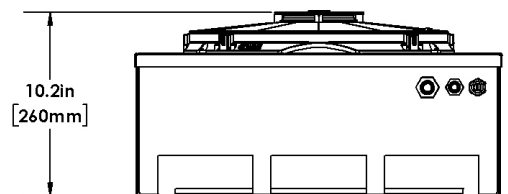
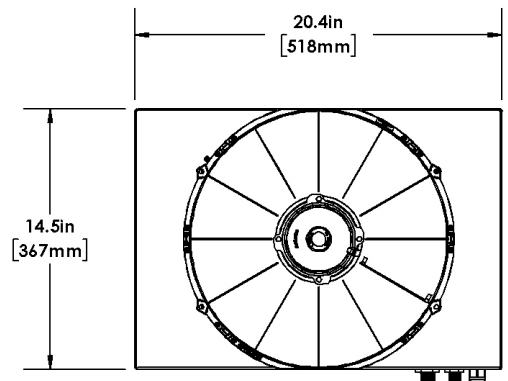

OPTIONS

- Remote Evaporator
- Remote Compressor
- Refrigeration Hose Kit
- Attached Drier

SERVICE PARTS

<u>Part No.</u>	
10-10-0060.....	Condenser Coil
14-10-1410.....	Condenser Fan 12VDC
14-10-1411.....	Condenser Fan 24VDC
13-10-1010.....	Drier
12-10-3000.....	Binary/Pressure Switch
16-19-2002.....	Schrader Valve

CONDENSER — ROOFTOP — BACK WALL

43-3025

CONSTRUCTION • AGRICULTURE • FORESTRY • TRUCKS • UNIVERSAL

The 3025 is a rugged, low profile Condenser perfect for back of day cabs or any cab where space is limited and superior performance is needed. A perfect match for any 16,000-20,000 BTU Evaporator. Available with optional attached drier.



**Not Sure What To Order?
We Can Help . . .**

**See the A/C System
Configuration Worksheet
on the last page of this catalog.**

<http://www.visionaire-inc.com>
866-838-2810

PART NO.

43-3025-100012VDC
43-3025-200024VDC

SHIPPING NOTICE

This unit can be shipped by UPS or LTL.

SPECIFICATIONS

Capacity.....24,000 BTU/hr
Current Draw 11 amps @ 12VDC5.5 amps @ 24VDC
Weight36 LBS
Condenser CoilAluminum Multiflow
Dimensions.....24.6" L x 14.4" W x 5.7" H
Motor 14" Condenser Fan

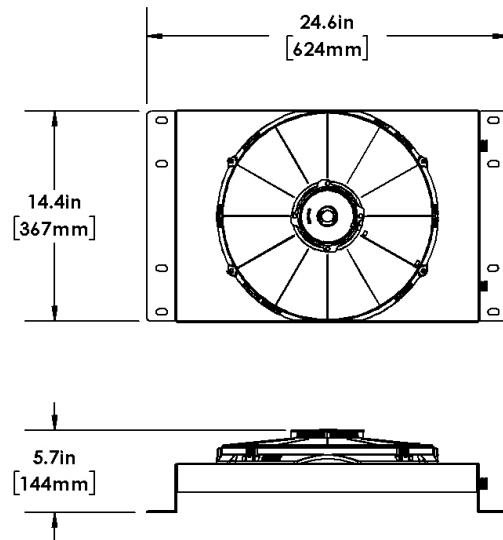

OPTIONS

- Remote Evaporator
 - Attached Drier
- Remote Compressor
 - Refrigeration Hose Kit

SERVICE PARTS

Part No.

10-10-3025.....	Condenser Coil
14-10-1410.....	Condenser Fan 12VDC
14-10-1411.....	Condenser Fan 24VDC
13-10-1005.....	Drier
30-0000-210.....	Drier Bracket
35-3025-002.....	Drier Tube

CONDENSER — BACK WALL

43-3030

CONSTRUCTION • AGRICULTURE • FORESTRY • UNIVERSAL

The 3030 features various mounting configurations and a low profile design, making it easily adaptable to most vehicles. Ideal for use with any mid-size evaporators, including the model 4050, 4050M and 4030.

**Not Sure What To Order?
We Can Help . . .**

**See the A/C System
Configuration Worksheet
on the last page of this catalog.**

<http://www.visionaire-inc.com>
866-838-2810



PART NO.

43-3030-1112 12VDC

43-3030-2112 24VDC

SHIPPING NOTICE

This unit can be shipped by UPS or LTL.

SPECIFICATIONS

Capacity..... 32,000 BTU/hr
 Current Draw 15 amps @ 12VDC 7 amps @ 24VDC
 Weight 38 LBS
 Condenser Coil Aluminum Multiflow
 Dimensions..... 29.7" L x 17.6" W x 8.2" H
 Motor 12" Condenser Fan

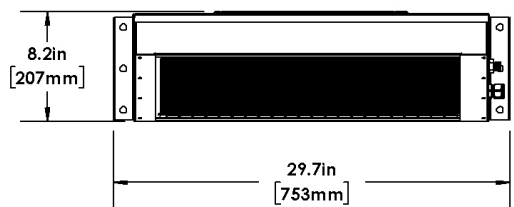
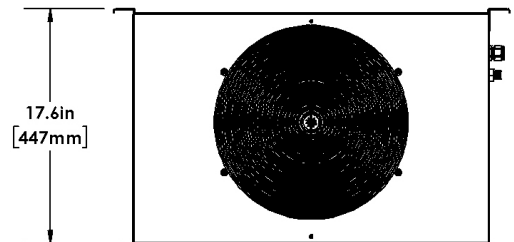

OPTIONS

- Remote Evaporator
- Remote Compressor
- Refrigeration Hose Kit

SERVICE PARTS

Part No.

10-10-3030.....Condenser Coil
 12-10-3000.....Binary/Pressure Switch
 13-10-1005.....Drier
 14-10-1220.....Condenser Fan 12VDC
 14-10-1221.....Condenser Fan 24VDC

CONDENSER — ROOFTOP — BACK WALL

43-3060

CONSTRUCTION • AGRICULTURE • FORESTRY • RAIL • UNIVERSAL

Model 3060 is a high capacity single fan condenser design for large cab applications. It can be used in conjunction with the model 4161 Evaporator or other high capacity evaporators.

**Not Sure What To Order?
We Can Help . . .**

**See the A/C System
Configuration Worksheet
on the last page of this catalog.**

<http://www.visionaire-inc.com>

866-838-2810



PART NO.

43-3060-1112 12VDC

43-3060-2112 24VDC

SHIPPING NOTICE

This unit can be shipped by UPS or LTL.

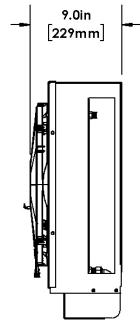
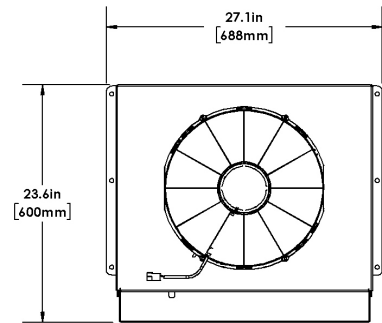

SPECIFICATIONS

Capacity.....45,000 BTU/hr
 Current Draw 12 amps @ 12VDC6 amps @ 24VDC
 Weight50 LBS
 Condenser Coil Copper Tubing Aluminum Fin
 Dimensions.....27.1" L x 23.6" W x 9" H
 Motor 16" Condenser Fan

OPTIONS

- Remote Evaporator
- Remote Compressor
- Refrigeration Hose Kit

SERVICE PARTS

Part No.

10-10-7070Condenser Coil
 14-10-1610Condenser Fan 12VDC
 14-10-1611Condenser Fan 24VDC
 13-10-3000Drier
 12-10-3000Binary/Pressure Switch

CONDENSER — SKIRT MOUNT — BACK WALL

43-3081

CONSTRUCTION • BUS • UNIVERSAL

The 3081 is a 3 fan high capacity condenser ideal for use with large or multiple mid-size evaporators. Various mounting configurations makes this easily adaptable to most vehicles. Drier, bracket mount and drier bracket ships uninstalled for versatile mounting.

**Not Sure What To Order?
We Can Help . . .**

**See the A/C System
Configuration Worksheet
on the last page of this catalog.**

<http://www.visionaire-inc.com>
866-838-2810



PART NO.

43-3081-1000 12VDC

43-3081-2000 24VDC

SHIPPING NOTICE

Due to the size and weight this unit must be shipped LTL.

SPECIFICATIONS

Capacity.....82,000 BTU/hr
 Current Draw30 amps @ 12VDC15 amps @ 24VDC
 Weight50 LBS
 Condenser CoilCopper Tubing Aluminum Coated Fin
 Dimensions.....51" L x 15.8" W x 10.3" H
 Motor12" Condenser Fan

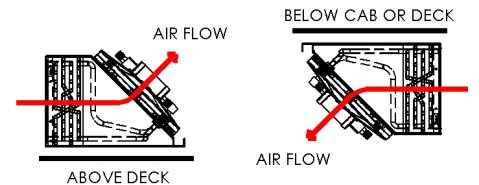
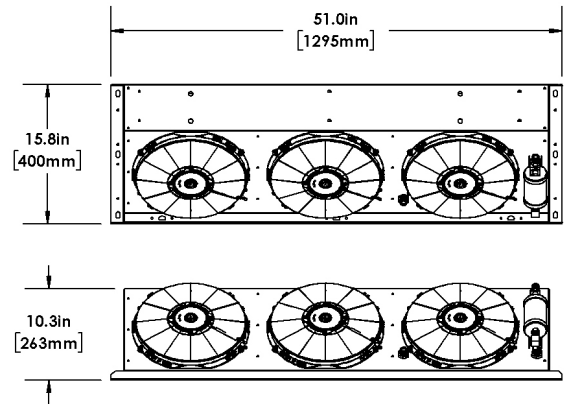

OPTIONS

- Remote Evaporator
- Remote Compressor
- Refrigeration Hose Kit
- Condenser Guard (30-3080-006)

SERVICE PARTS

Part No.	
10-10-3081	Condenser Coil
14-10-1230	Condenser Fan 12VDC
14-10-1231	Condenser Fan 24VDC
13-10-3000	Drier

CONDENSER — SKIRT MOUNT — BACK WALL

43-3040

CONSTRUCTION • AGRICULTURE • FORESTRY • UNIVERSAL

The 3040 Single Fan Wedge Condenser is a design that has stood the test of time. Heavy duty aluminum construction, high capacity, and multiple mounting configurations. Available in both 12/24 Volt configurations and with left or right hand side connection points.

**Not Sure What To Order?
We Can Help . . .**

**See the A/C System
Configuration Worksheet
on the last page of this catalog.**

<http://www.visionaire-inc.com>

866-838-2810



PART NO.

43-3040-1112.....12VDC

43-3040-2112.....24VDC

SHIPPING NOTICE

This unit can be shipped by UPS or LTL.

SPECIFICATIONS

Capacity.....41,800 BTU/hr
 Current Draw11.5 amps @ 12VDC6 amps @ 24VDC
 Weight36 LBS
 Condenser CoilCopper Tubing Aluminum Fin
 Dimensions.....29.46" L x 12.26" W x 11.36" H
 Motor12" Condenser Fan

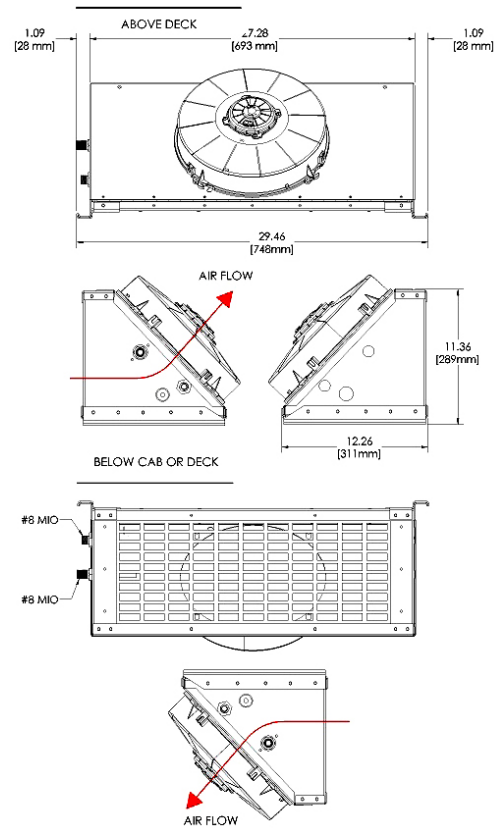

OPTIONS

- Remote Evaporator
- Remote Compressor
- Alternate Side Hose Kit

SERVICE PARTS

Part No.	
10-10-3040	Coil
12-10-3000	Binary/Pressure Switch
13-10-3000	Drier
14-10-1250	Fan
33-3040-001	Wire Harness

CONDENSER — SKIRT MOUNT — BACK WALL

43-3045

CONSTRUCTION • AGRICULTURE • FORESTRY • UNIVERSAL

The 3045 Dual Fan Wedge Condensor utilizes the same footprint as the 3040 but packs a bigger punch. Heavy duty aluminum construction, high capacity, and multiple mounting configurations. Available in both 12/24 Volt configurations and with left or right hand side connection points.

**Not Sure What To Order?
We Can Help . . .**

**See the A/C System
Configuration Worksheet
on the last page of this catalog.**

<http://www.visionaire-inc.com>
866-838-2810



PART NO.

43-3045-1112.....12VDC

43-3045-2112.....24VDC

SHIPPING NOTICE

This unit can be shipped by UPS or LTL.

SPECIFICATIONS

Capacity.....47,400 BTU/hr
 Current Draw23 amps @ 12VDC13 amps @ 24VDC
 Weight40 LBS
 Condenser CoilCopper Tubing Aluminum Fin
 Dimensions.....29.46" L x 12.26" W x 11.36" H
 Motor12" Condenser Fan

OPTIONS

- Remote Evaporator
- Remote Compressor
- Alternate Side Hose Kit

SERVICE PARTS

Part No.	
10-10-3040	Coil
12-10-3000	Binary/Pressure Switch
13-10-3000	Drier
14-10-1230	Fan
33-3040-001	Wire Harness

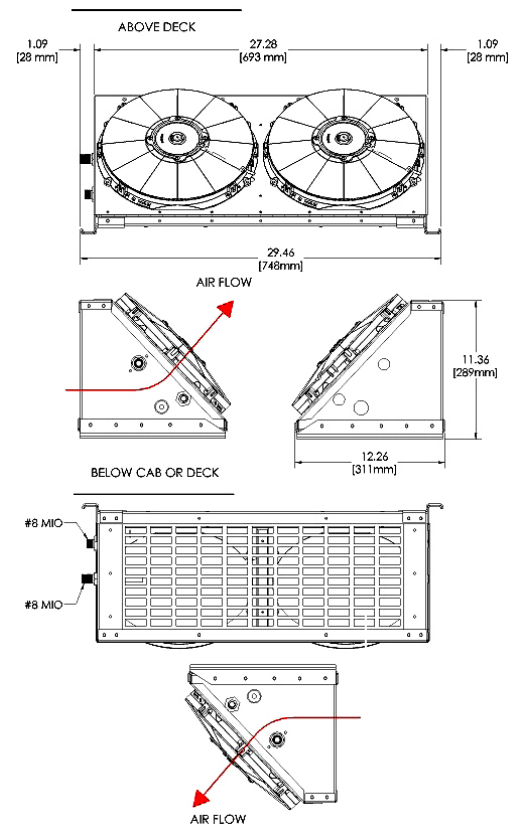

CONDENSER — ROOFTOP — BACK WALL 43-3085

CONSTRUCTION • AGRICULTURE • FORESTRY • RAIL • UNIVERSAL

The 3085 is a high capacity and versatile unit that can be mounted to a vertical or horizontal surface. Slim profile design and steel construction are a winning combination for the toughest of jobs. This unit is designed to be paired with high capacity evaporators.

**Not Sure What To Order?
We Can Help . . .**

**See the A/C System
Configuration Worksheet
on the last page of this catalog.**

<http://www.visionaire-inc.com>

866-838-2810

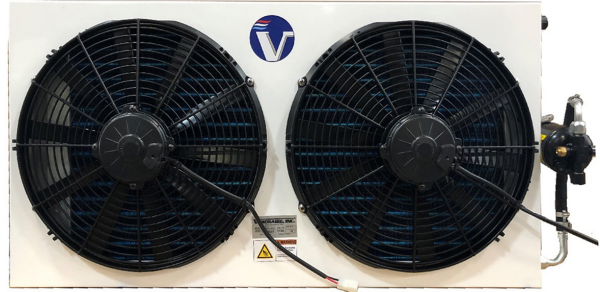

PART NO.

43-3085-1000 12VDC

43-3085-2000 24VDC

SHIPPING NOTICE

This unit can be shipped by UPS or LTL.

SPECIFICATIONS

- Capacity.....77,000 BTU/hr
- Current Draw32 amps @ 12VDC16 amps @ 24VDC
- Weight52 LBS
- Condenser CoilCopper Tubing Aluminum Fin
- Dimensions.....37.2" L x 18.4" W x 8.9" H
- Motor16" Condenser Fan

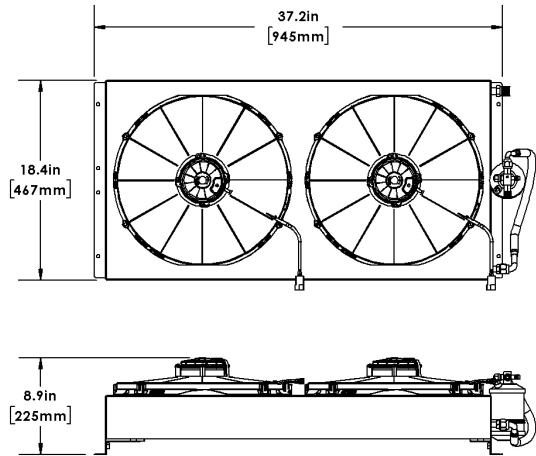

OPTIONS

- Remote Evaporator
- Remote Compressor
- Refrigeration Hose Kit

SERVICE PARTS

Part No.

- 10-10-3085..... Condenser Coil
- 14-10-1612..... Condenser Fan 12v
- 14-10-1613..... Condenser Fan 24v
- 13-10-2003..... Drier

CONDENSER — ROOFTOP — BACK WALL

43-3110

CONSTRUCTION • AGRICULTURE • FORESTRY • UNIVERSAL

The 3110 is both a Condenser and Hydraulic* Drive Compressor in one convenient package. Saves on space and makes for ease of installation. Ideal for use on boom trucks and oilfield cabs.

**Not Sure What To Order?
We Can Help . . .**

**See the A/C System
Configuration Worksheet
on the last page of this catalog.**

<http://www.visionaire-inc.com>

866-838-2810



PART NO.

43-3110-1100 12VDC

43-3110-2100 24VDC

SHIPPING NOTICE

Due to the size and weight this unit must be shipped LTL.

*Flow Rate and Pressure/PSI Needs Confirmed Prior to Purchase

SPECIFICATIONS

Capacity.....25,500 BTU/hr
 Current Draw 12 amps @ 12VDC6 amps @ 24VDC
 Weight 105 LBS
 Condenser Coil Copper Tubing Aluminum Fin
 Dimensions.....23.8" L x 17.4" W x 14.7" H
 Motor 14" Condenser Fan

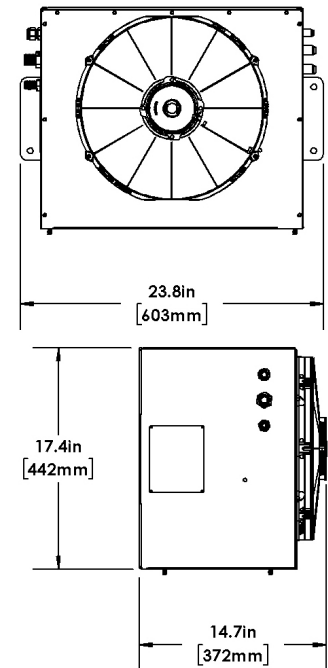

OPTIONS

- Remote Evaporator
- Refrigeration Hose Kit

SERVICE PARTS

Part No.

10-10-7110..... Condenser Coil
 12-10-3000..... Binary/Pressure Switch
 13-10-1005..... Drier
 14-10-1410..... Cond Fan 12VDC
 14-10-1411..... Cond Fan 24VDC

Part No.

11-10-0032..... Compressor
 14-80-0209..... Hyd Motor

CONDENSER — ROOFTOP — BACK WALL

43-3130

CONSTRUCTION • AGRICULTURE • FORESTRY • UNIVERSAL

The 3130 is a heavy duty, steel forced air condenser with Hydraulic* Driven Compressor. Mounts on roof-top or outside wall. Pair with 4030 evaporator for optimum performance.

**Not Sure What To Order?
We Can Help . . .**

**See the A/C System
Configuration Worksheet
on the last page of this catalog.**

<http://www.visionaire-inc.com>

866-838-2810



PART NO.

43-3130-1112 12VDC

43-3130-2112 24VDC

SHIPPING NOTICE

Due to the size and weight this unit must be shipped LTL.

*Flow Rate and Pressure/PSI Needs Confirmed Prior to Purchase

SPECIFICATIONS

Capacity.....32,000 BTU/hr
 Current Draw20 amps @ 12VDC 12 amps @ 24VDC
 Weight 105 LBS
 Condenser CoilAluminum Multiflow
 Dimensions.....27.1" L x 26.7" W x 8.1" H
 Motor 12" Condenser Fan

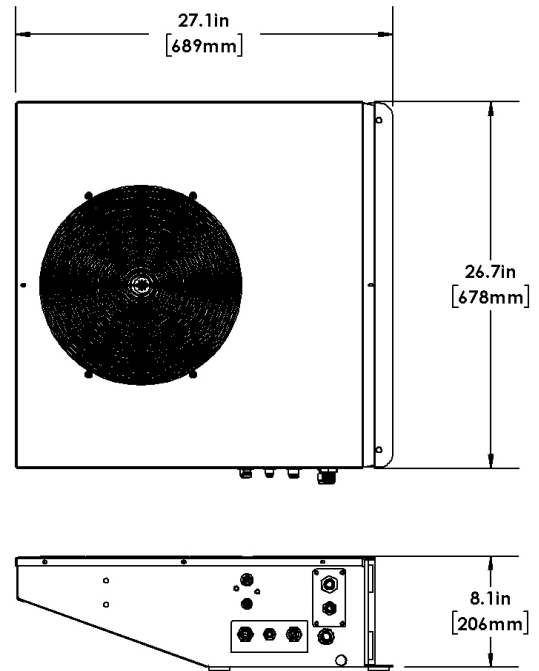

OPTIONS

- Remote Evaporator
- Refrigeration Hose Kit

SERVICE PARTS

Part No.

10-10-3030.....Condenser Coil
 14-10-1220.....Condenser Fan 12VDC
 14-10-1221.....Condenser Fan 24VDC
 11-10-0030.....Compressor

Part No.

14-80-0210.....Hyd Motor 12VDC
 14-80-0220.....Hyd Motor 24VDC
 13-10-1005.....Drier
 12-10-3000.....Binary/Pressure Switch



CONDENSER — ROOFTOP

891029-12VDC

CONSTRUCTION • ON & OFF-ROAD • FORESTERY

Passenger van (Sprinter/Transit Vans) HVAC

The 891029-12V is a high performance, aluminum framed casing- roof mounted condensing unit. Perfect aftermarket solution for medium sized cabs / passenger vans.

**Not Sure What To Order?
We Can Help . . .**

**See the A/C System
Configuration Worksheet
on the last page of this catalog.**

<https://atc.ca>

800-295-4156

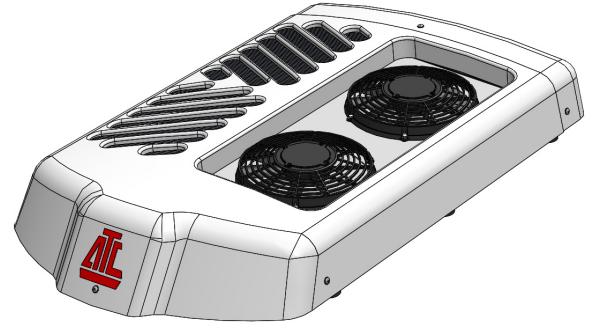

PART NO.

891029 12VDC Condenser unit

SHIPPING NOTICE

Due to the size and weight this unit must be shipped LTL.

SPECIFICATIONS

Air Flow..... 1,800 CFM
Capacity..... 65,600 BTU/hr
Current Draw 21 amps @ 12VDC
Weight 60 LBS
Condenser Coil Copper Tubing / Aluminum Fin
Dimensions..... 51.6250" L x 33.5" W x 7.6250" H
Motor 11" Fans

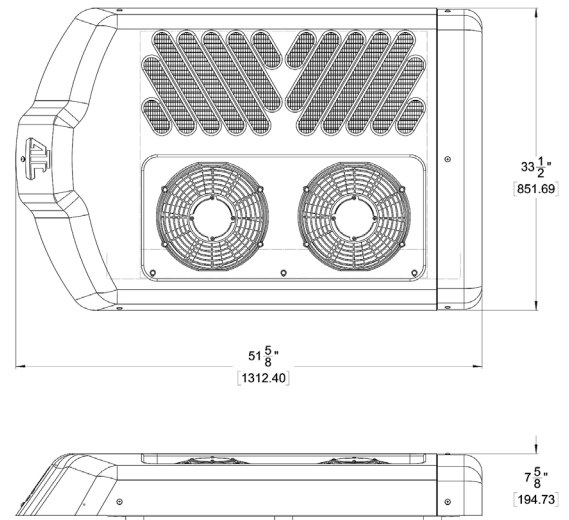

OPTIONS

- 810025 - Digital Controller
- 820086-12/24VDC - Relay Box / Wiring Harness
- Engine Driven Compressor
- Refrigeration Hose Kit

SERVICE PARTS

Part No.

M970273 Condenser Coil
M910132 Cond. Pull Fan 12VDC
7502..... Drier



CONDENSER — ROOFTOP — BACK WALL 891005-12/24VDC - AC

CONSTRUCTION • ON & OFF-ROAD • FORESTRY

The 6000 is a heavy duty, powder coated black steel casing -Low profile micro-channel electric condenser. Perfect for small to medium size cabs.

**Not Sure What To Order?
We Can Help . . .**

**See the A/C System
Configuration Worksheet
on the last page of this catalog.**

<https://atc.ca>
800-295-4156

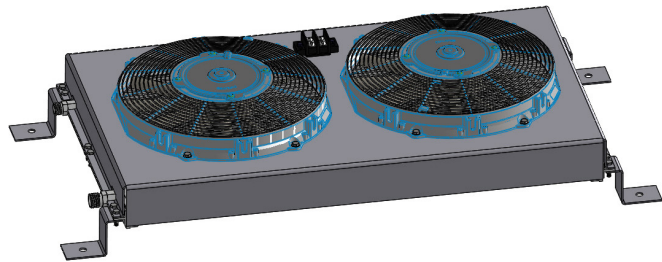

PART NO.

89100512/24VDC

SHIPPING NOTICE

This unit can be shipped by UPS or LTL.

SPECIFICATIONS

Air Flow..... 1,200 CFM
Capacity.....28,000 BTU/hr
Current Draw 14 amps @ 12VDC7 amps @ 24VDC
Weight 15 LBS
Condenser CoilAluminum Multiflow
Dimensions.....30.5625" L x 14" W x 5.8750" H
Motor 10" Fans

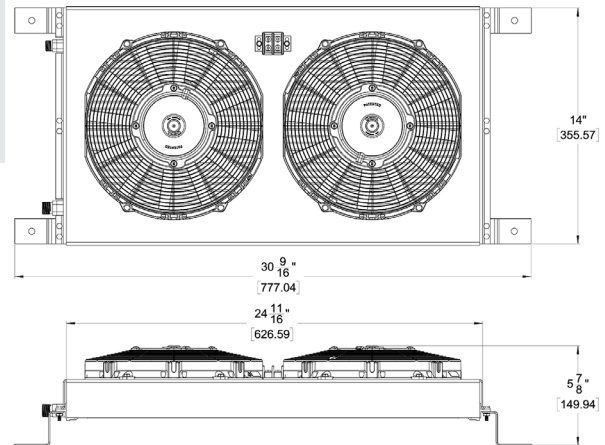

OPTIONS

- 810025 - Digital controller
- 820086-12/24VDC - Relay Box / Wiring Harness
- Engine Driven Compressor
- Refrigeration Hose Kit

SERVICE PARTS

Part No.

6310..... Condenser Coil
3560..... 10" Pull Fan
N/A..... External Water Valve Option



CONDENSER — ROOFTOP

891024-12V

CONSTRUCTION • ON & OFF-ROAD • FORESTRY

The 891024-12V is a high performance, aluminum framed casing-roof mounted condensing unit.

**Not Sure What To Order?
We Can Help . . .**

**See the A/C System
Configuration Worksheet
on the last page of this catalog.**

<https://atc.ca>

800-295-4156

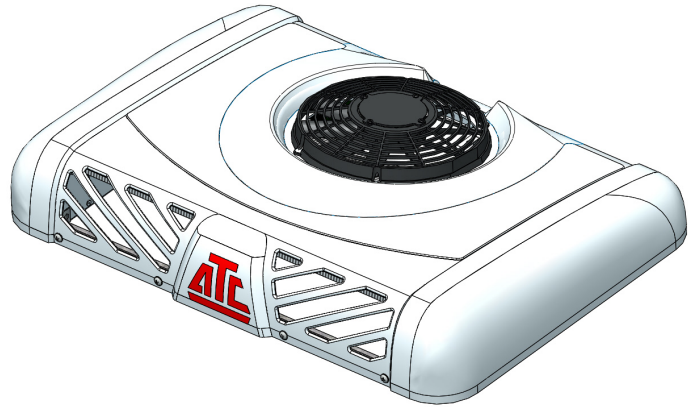

PART NO.

891024 12VDC

SHIPPING NOTICE

This unit can be shipped by UPS or LTL.

SPECIFICATIONS

Air Flow..... 930 CFM
 Capacity..... 32,000 BTU/hr
 Current Draw 8.6 amps @ 12VDC
 Weight 35 LBS
 Condenser Coil Copper Tubing / Aluminum Fin
 Dimensions..... 25.75"L x 36.3125" W x 6.3125" H
 Motor 11" Fan

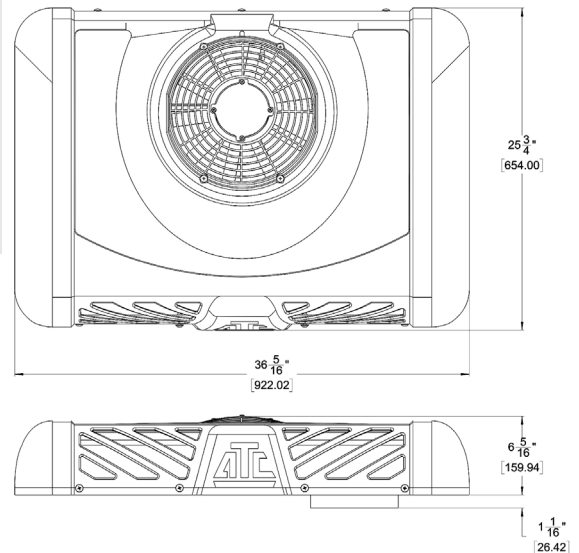

OPTIONS

- 810025 - Digital controller
- 820086-12/24VDC - Relay Box / Wiring Harness
- Engine Driven Compressor
- Refrigeration Hose Kit

SERVICE PARTS

Part No.

M970271 Condenser Coil
 M910132 11" Pull Fan
 7502..... Drier
 4150..... Sight Glass (moist Ind.)

CONDENSER — ROOFTOP — WALL MOUNT

891008-12/24V

CONSTRUCTION • ON & OFF-ROAD • FORESTRY

The 6015 is a heavy duty, high profile, powder coated black steel condenser - perfect for small to medium size cabs.

Not Sure What To Order?
We Can Help . . .

See the A/C System
Configuration Worksheet
on the last page of this catalog.

<https://atc.ca>

800-295-4156

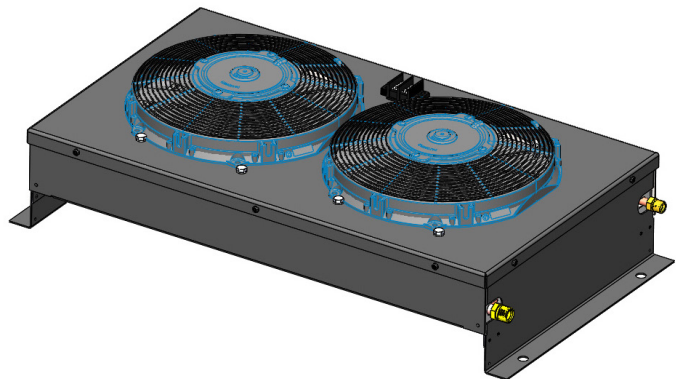

PART NO.

891008 12VDC

891008 24VDC

SHIPPING NOTICE

This unit can be shipped by UPS or LTL.

SPECIFICATIONS

Air Flow.....1,200 CFM
Capacity.....25,000 BTU/hr
Current Draw14 amps @ 12VDC8 amps @ 24VDC
Weight28 LBS
Condenser CoilCopper Tubing / Aluminum Fin
Dimensions.....27.75" L x 14.625" W x 7.25" H
Motor10" Fans

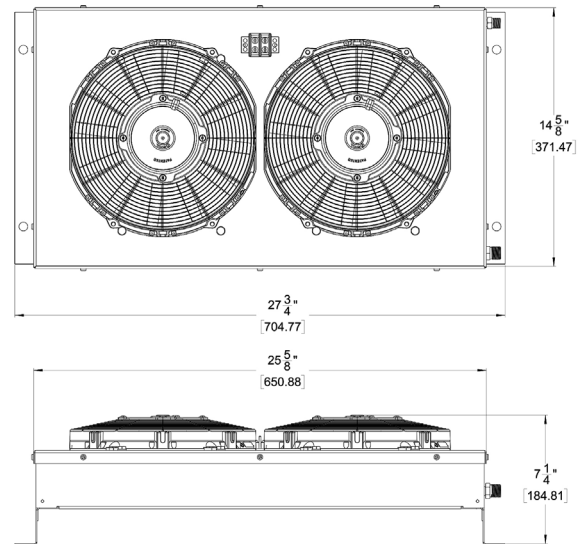

OPTIONS

- 810025 - Digital Controller
- 820086-12/24VDC - Relay Box / Wiring Harness
- Engine Driven Compressor
- Refrigeration Hose Kit

SERVICE PARTS

Part No.

875002ACondenser Coil
3560.....10" Pull Fan-12VDC
3561.....10" Pull Fan 24VDC



CONDENSER — ROOFTOP — WALL MOUNT

891027-12/24 VDC

CONSTRUCTION • ON & OFF-ROAD • FORESTRY

The 891027-12/24 VDC is a heavy duty, high profile, high capacity, powder coated black steel casing condenser - perfect for small to medium size cabs.

Not Sure What To Order?
We Can Help . . .

See the A/C System
Configuration Worksheet
on the last page of this catalog.

<https://atc.ca>

800-295-4156

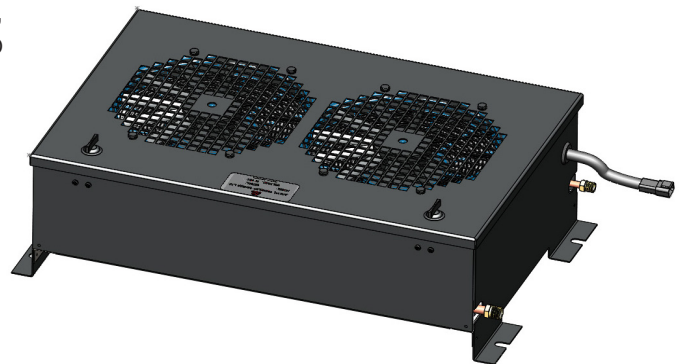

PART NO.

891027 12VDC

891027 24VDC

SHIPPING NOTICE

This unit can be shipped by UPS or LTL.

SPECIFICATIONS

Air Flow.....1,200 CFM
Capacity.....45,000 BTU/hr
Current Draw14 amps @ 12VDC8 amps @ 24VDC
Weight34.5 LBS
Condenser CoilCopper Tubing / Aluminum Fin
Dimensions.....27.8750" L x 16.9375" W x 8.3750" H
Motor10" Fans

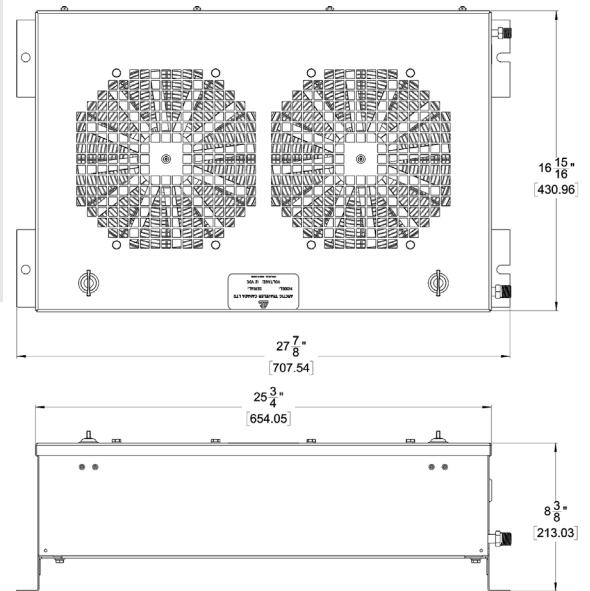

OPTIONS

- 810025 - Digital Controller
- 820086-12/24VDC - Relay Box / Wiring Harness
- Engine Driven Compressor
- Refrigeration Hose Kit

SERVICE PARTS

Part No.

875117.....Condenser Coil
M910147 10" Push Fan-12VDC
3584..... 10" Push Fan 24VDC

CONDENSER — ROOFTOP — BEHIND CAB — FLOOR MOUNT

HA-100-12-HD
HA-100-24-HD

CONSTRUCTION • FORESTRY • MINING • BULLDOZER

Heavy Duty Condenser - 10" x 24" 5 row copper/aluminum coil with 1/4" base plate, 3/16" shell and drier.

**Not Sure What To Order?
We Can Help . . .**

**See the A/C System
Configuration Worksheet
on the last page of this catalog.**

<https://www.hammondac.com>

800-267-2665

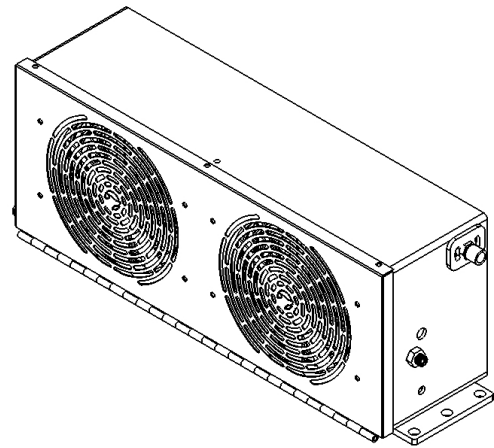

PART NO.

HA-100-12-HD 12VDC
HA-100-24-HD 24VDC

SHIPPING NOTICE

Due to size and weight this unit must be shipped LTL.

SPECIFICATIONS

Air Flow.....1180 CFM
Capacity.....36,000 BTU/hr
Current Draw12 amps @ 12VDC6 amps @ 24VDC
Weight75 LBS
Condenser CoilCopper Tubing Aluminum Fin
Dimensions.....30.6" L x 8.4" W x 11.1" H
Motor9" Condenser Fans

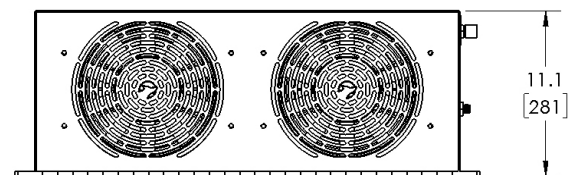
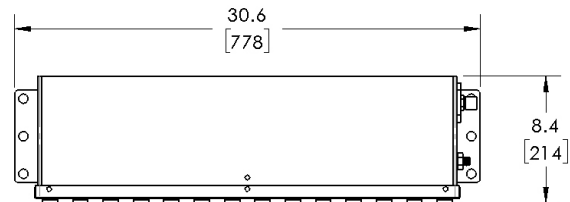

- OPTIONS**
- Right or Left Hand Configurations
 - HA-100-ZA - Z Bracket Assembly for Behind Cab Mounting

SERVICE PARTS

Part No.

420-860 Condenser Coil
430-038 9" Power Fan, 12V Pusher
430-009 9" Power Fan, 24V Pusher
523-052-9..... Receiver Drier
523-100-HD..... Drier Bracket
430-006 Fan Mounting Feet

Part No.

520-HD100-2A..... Hinged Fan Cover
HA-102..... Intake Screen
440-091 #8 Securing Lug

CONDENSER — WALL MOUNT

HA-100-12-HD-VERT
HA-100-24-HD-VERT

CONSTRUCTION • FORESTRY • MINING • BULLDOZER

Heavy Duty Condenser - 10" x 24" 5 row copper/aluminum coil with 1/4" base plate, 3/16" shell and drier.

**Not Sure What To Order?
We Can Help . . .**

**See the A/C System
Configuration Worksheet
on the last page of this catalog.**

<https://www.hammondac.com>

800-267-2665

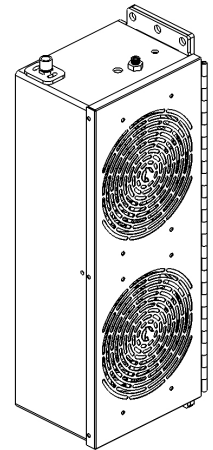

PART NO.

HA-100-12-HD-VERT 12VDC
HA-100-24-HD-VERT 24VDC

SHIPPING NOTICE

Due to size and weight this unit must be shipped LTL.

SPECIFICATIONS

Air Flow..... 1180 CFM
Capacity..... 36,000 BTU/hr
Current Draw 12 amps @ 12VDC 6 amps @ 24VDC
Weight 75 LBS
Condenser Coil Copper Tubing Aluminum Fin
Dimensions..... 11.1" L x 8.4" W x 30.6" H
Motor 9" Condenser Fans

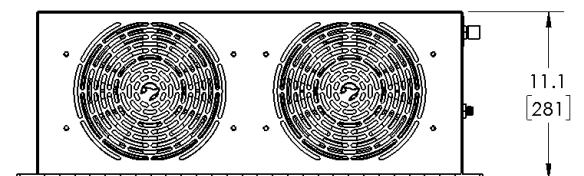
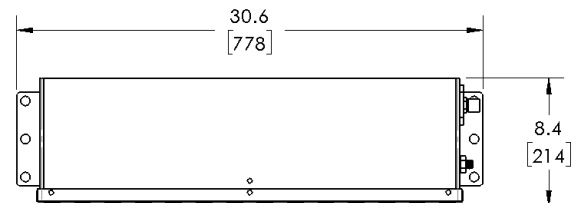

OPTIONS • Right or Left Hand Configurations

SERVICE PARTS

Part No.

420-860 Condenser Coil
430-038 9" Power Fan, 12V Pusher
430-009 9" Power Fan, 24V Pusher
523-092-9 Receiver Drier
523-HD100-7 Drier Bracket

Part No.

430-006 Fan Mounting Feet
520-HD100-2A Hinged Fan Cover
HA-102 Intake Screen
440-091 #8 Securing Lug

CONDENSER — FOOT MOUNT

HA-100-3-LRG-12
HA-100-3-LRG

CONSTRUCTION • FORESTRY • MINING • UNIVERSAL

12" x 32" 5 row copper/aluminum coil with steel shell, three 10" power fans and drier.

**Not Sure What To Order?
We Can Help . . .**

**See the A/C System
Configuration Worksheet
on the last page of this catalog.**

<https://www.hammondac.com>

800-267-2665

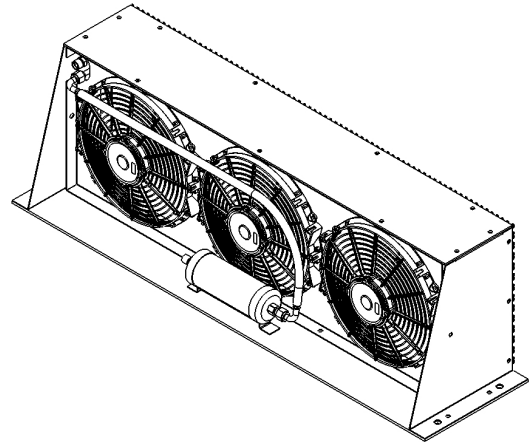

PART NO.

HA-100-3-LRG-12..... 12VDC
HA-100-3-LRG 24VDC

SHIPPING NOTICE

Due to size and weight this unit must be shipped LTL.

SPECIFICATIONS

Air Flow.....2406 CFM
Capacity.....55,000 BTU/hr
Current Draw28 amps @ 12VDC14 amps @ 24VDC
Condenser CoilCopper Tubing Aluminum Fin
Dimensions.....40" L x 10.43" W x 12.55" H
Motor10" Condenser Fans

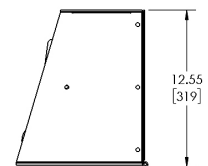
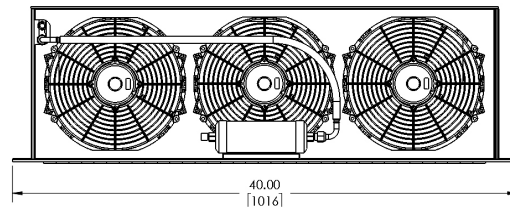
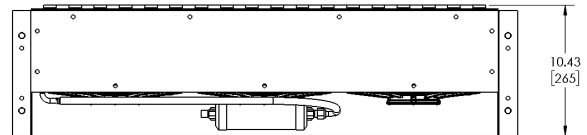

OPTIONS • N/A

SERVICE PARTS

Part No.	
420-800A.....	Condenser Coil
430-020A.....	10" Power Fan, 24V Puller
430-021	10" Power Fan, 12V Puller
523-063-9.....	Receiver Drier
301-215-2.....	Condenser Screen

CONDENSER — UNIVERSAL

420-904-100-12
420-904-100-24

UNIVERSAL

3 row copper/aluminum coil with steel shroud and two 10" power fans.

**Not Sure What To Order?
We Can Help . . .**

**See the A/C System
Configuration Worksheet
on the last page of this catalog.**

<https://www.hammondac.com>
800-267-2665

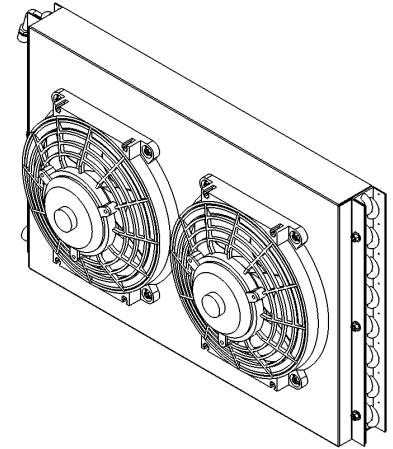

PART NO.

420-904-100-12..... 12VDC
420-904-100 24VDC

SHIPPING NOTICE

This unit can be shipped by UPS or LTL.

SPECIFICATIONS

Air Flow..... 1710 CFM
Capacity.....25,000 BTU/hr
Current Draw 16 amps @ 12VDC8 amps @ 24VDC
Weight25 LBS
Condenser CoilCopper Tubing Aluminum Fin
Dimensions.....27.74" L x 6.37" W x 16.27" H
Motor 10" Condenser Fans

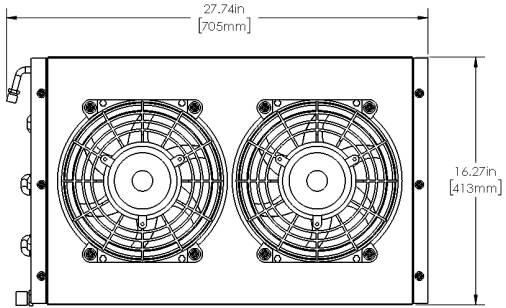
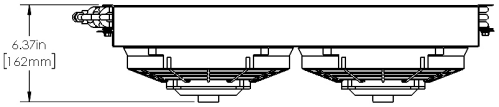

- OPTIONS**
- Variety of Mounting and Standoff Brackets
 - Steel Shroud

SERVICE PARTS

Part No.

420-904 Condenser Coil
430-04 10" Power Fan - 12V Puller
430-02 10" Power Fan - 24V Puller
520-BRON-50 16x24 Fan Shroud - 2 10" Fans

CONDENSER — UNIVERSAL

420-860-977-12
420-860-977

CONSTRUCTION • FORESTRY • MINING • UNIVERSAL

5 row copper/aluminum coil with 12 gauge steel shroud and two 9" power fans.

**Not Sure What To Order?
We Can Help . . .**

**See the A/C System
Configuration Worksheet
on the last page of this catalog.**

<https://www.hammondac.com>

800-267-2665

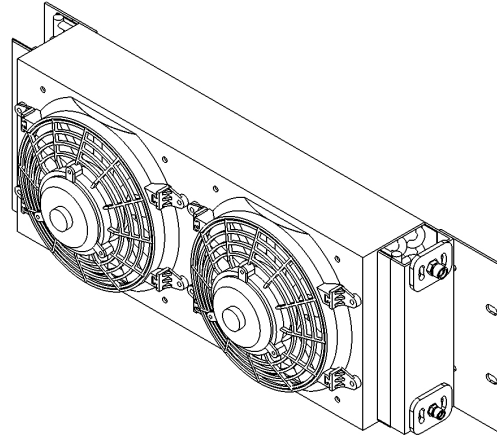

PART NO.

420-860-977-1212VDC

420-860-97724VDC

SHIPPING NOTICE

This unit can be shipped by UPS or LTL.

SPECIFICATIONS

Air Flow..... 1180 CFM
Capacity..... 36,000 BTU/hr
Current Draw 12 amps @ 12VDC 6 amps @ 24VDC
Condenser Coil Copper Tubing Aluminum Fin
Weight 45 LBS
Dimensions..... 31.38" L x 10.31" W x 7.63" H
Motor 9" Condenser Fans

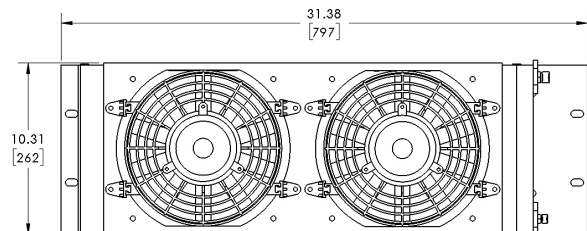
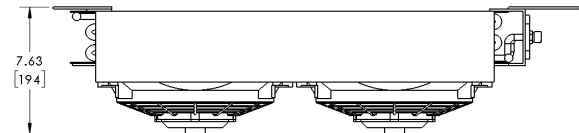

OPTIONS • 3/16" Shroud

SERVICE PARTS

Part No.

420-860-977-1 Condenser Coil
430-008 9" Power Fan, 24V Puller
430-039 9" Power Fan, 12V Puller
430-006 Fan Mounting Feet

440-090 #6 Securing Lug
440-091 #8 Securing Lug

CONDENSER — UNIVERSAL

**420-855-NEXG
420-855-NEXG-24**

UNIVERSAL

Multiflow condenser with aluminum shroud and two 10" power fans.

**Not Sure What To Order?
We Can Help . . .**

**See the A/C System
Configuration Worksheet
on the last page of this catalog.**

<https://www.hammondac.com>

800-267-2665

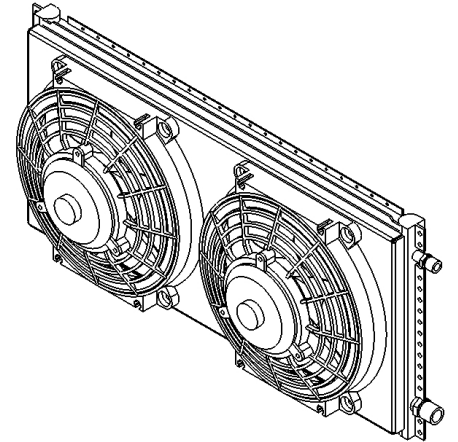

PART NO.

420-855-NEXG 12VDC
420-855-NEXG-24 24VDC

SHIPPING NOTICE

This unit can be shipped by UPS or LTL.

SPECIFICATIONS

Air Flow.....802 CFM
Capacity.....18,000 BTU/hr
Current Draw6 amps @ 12VDC
Weight13 LBS
Dimensions.....26.5" L x 12.20" W x 5.38" H
Condenser CoilAluminum Multiflow
Motor10" Condenser Fans

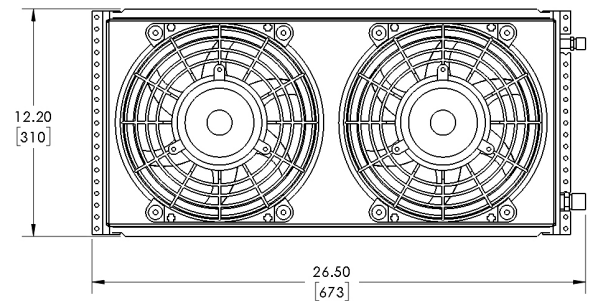
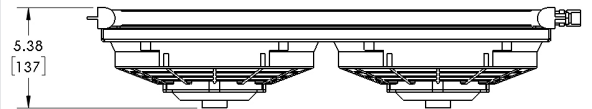

- OPTIONS**
- Variety of Mounting and Standoff Brackets
 - Steel Shroud

SERVICE PARTS

Part No.

420-855 Condenser Coil
430-040-DFW 10" Power Fan - 12VDC Puller
430-020 10" Power Fan - 24VDC Puller

CONDENSER — UNIVERSAL

424-008-H50

UNIVERSAL

Multiflow condenser with steel shroud and two 10" power fans.

**Not Sure What To Order?
We Can Help . . .**

See the **A/C System
Configuration Worksheet**
on the last page of this catalog.

<https://www.hammondac.com>
800-267-2665

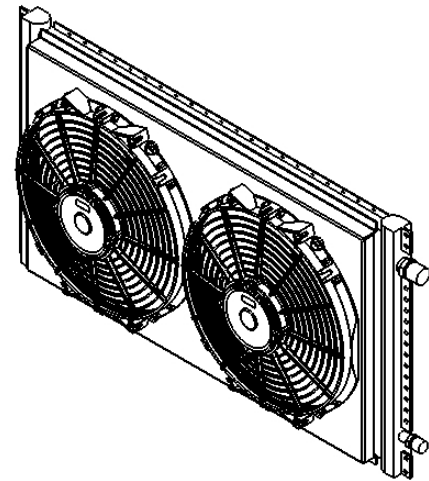

PART NO.

424-008-H5012VDC

SHIPPING NOTICE

This unit can be shipped by UPS or LTL.

SPECIFICATIONS

Air Flow.....708 CFM
Capacity.....19,000 BTU/hr
Current Draw6 amps @ 12VDC
Weight15 LBS
Condenser CoilAluminum Multiflow
Dimensions.....26.31" L x 14" W x 3.97" H
Motor10" Condenser Fans

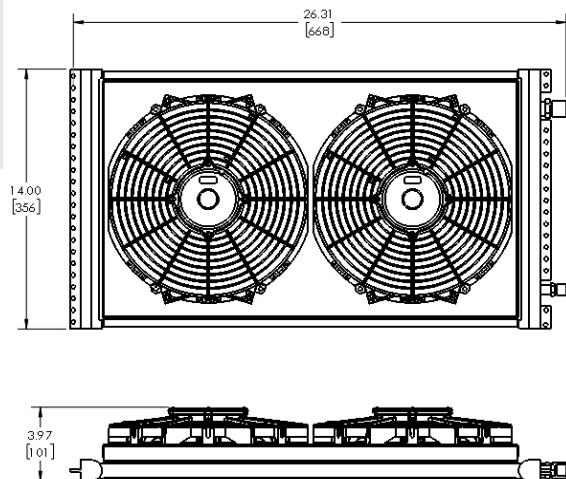

OPTIONS

- 24VDC Available upon request
- 520-H50-51 - Mounting Bracket

- One 12" Condenser Fan

SERVICE PARTS

Part No.

424-008Condenser Coil
430-02210" Power Fan - 12VDC Pusher

CONDENSER — WALL MOUNT

K TCK COND SPLIT

UNIVERSAL • HIGHWAY TRUCKS

4 row copper/aluminum coil with diamond plate aluminum shroud and one 11" power fan and drier.

**Not Sure What To Order?
We Can Help . . .**

**See the A/C System
Configuration Worksheet
on the last page of this catalog.**

<https://www.hammondac.com>

800-267-2665

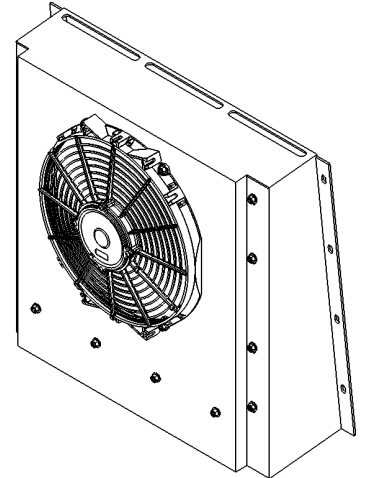

PART NO.

K TCK COND SPLIT 12VDC

SHIPPING NOTICE

This unit can be shipped by UPS or LTL.

SPECIFICATIONS

Air Flow.....932 CFM
Capacity.....28,000 BTU/hr
Current Draw9 amps @ 12VDC
Weight30 LBS
Condenser CoilCopper Tubing Aluminum Fin
Dimensions.....21.75" L x 20" W x 8.70" H
Motor 11" Condenser Fan

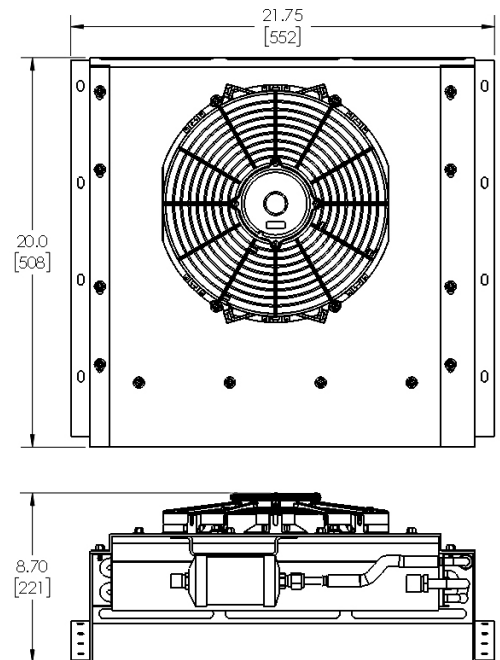

- OPTIONS**
- 24VDC Available upon request
 - Stainless Steel Shroud

SERVICE PARTS

Part No.	
420-909	Condenser Coil
430-002	11" Power Fan - 12VDC Puller
523-450-7	Receiver Drier

EVAPORATOR — ROOFTOP

44-4025

CONSTRUCTION • AGRICULTURE • FORESTRY • TRUCKS • UNIVERSAL

The 4025 is a heavy duty, roof mounted Evaporator/Heater for small cabs. Three speed blower offering 260 CFM. Perfect for skid steer, lift truck and other vehicles where space is limited.

**Not Sure What To Order?
We Can Help . . .**

**See the A/C System
Configuration Worksheet
on the last page of this catalog.**

<http://www.visionaire-inc.com>

866-838-2810



PART NO.

44-4025-1190 ACH..... 12VDC

44-4025-2190 ACH..... 24VDC

SHIPPING NOTICE

This unit can be shipped by UPS or LTL.

SPECIFICATIONS

Air Flow.....260 CFM
 Capacity.....Cooling 17,500 BTU/hr.....Heating 26,500 BTU/hr
 Current Draw 10 amps @ 12VDC5 amps @ 24VDC
 Weight40 LBS
 Evaporator CoilCopper Tubing Aluminum Fin
 Dimensions.....26.4" L x 22.2" W x 6.2" H
 Motor3 Speed Blower (low/med/high)

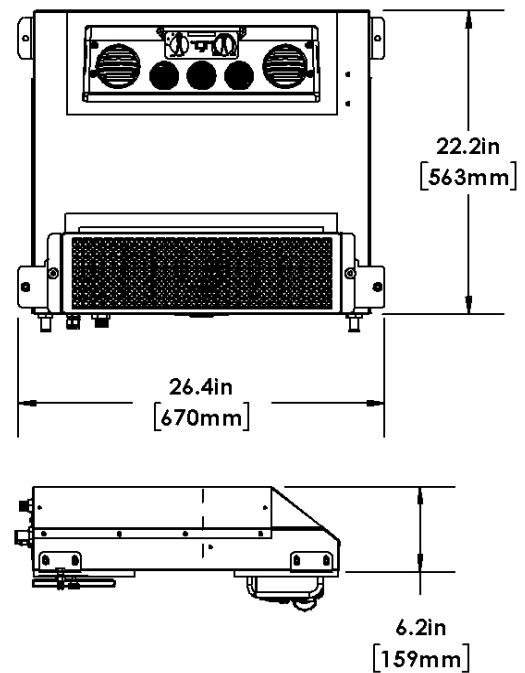

OPTIONS

- Remote Condenser
- Pressurizer Kit
- Refrigeration Hose Kit
- Mounting Feet

SERVICE PARTS

Part No.

10-10-4025..... Evap/Heater Coil
 12-11-2000..... Expansion Valve
 12-31-0001..... Heater Pull Cable
 12-54-1001..... Thermostat
 14-20-0042..... Blower Fan 12VDC

Part No.

14-20-0043..... Blower Fan 24VDC
 15-10-2001..... Air Filter

EVAPORATOR — ROOFTOP — BACK WALL

44-4030

CONSTRUCTION • AGRICULTURE • FORESTRY • TRUCKS • UNIVERSAL

The 44-4030 is a heavy duty, powder coated steel evaporator that mounts on the outside of a cab in a vertical or horizontal position. Perfect for medium size cabs. Pair with the 3030 Forced Air Condenser for optimum performance.

**Not Sure What To Order?
We Can Help . . .**

**See the A/C System
Configuration Worksheet
on the last page of this catalog.**

<http://www.visionaire-inc.com>
866-838-2810



PART NO.

44-4030-1040 ACH12VDC
44-4030-2040 ACH24VDC
44-4030-1041 AC Only12VDC
44-4030-2041 AC Only24VDC

SHIPPING NOTICE

This unit can be shipped by UPS or LTL.

SPECIFICATIONS

Air Flow..... 420 CFM
 Capacity..... Cooling 25,000 BTU/hr..... Heating 37,500 BTU/hr
 Current Draw 12.5 amps @ 12VDC6.3 amps @ 24VDC
 Weight62 LBS
 Evaporator Coil Copper Tubing Aluminum Fin
 Dimensions.....26.7" L x 21.1" W x 11.8" H
 Motor3 Speed Blower (low/med/high)

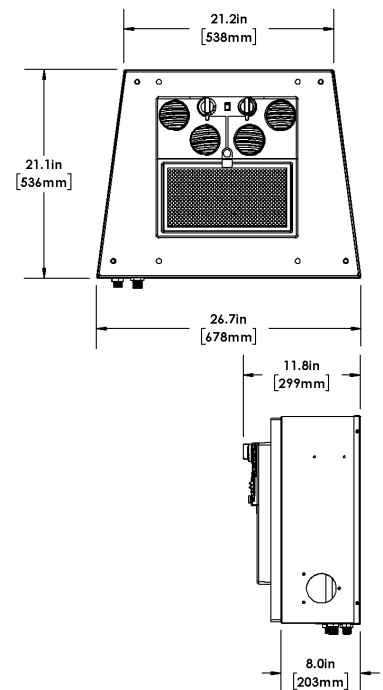

OPTIONS

- Remote Condenser
- Pressurizer Kit
- Refrigeration Hose Kit
- Heater Hose Kit

SERVICE PARTS

Part No.

10-20-4030 Evaporator Coil
 10-30-4030 Heater Coil
 14-20-0020 Blower Fan 12VDC
 14-20-0021 Blower Fan 24VDC
 12-11-1001 Expansion Valve

Part No.

15-10-1017 Return Air Filter
 12-31-0002 Mechanical Water Valve
 12-54-1001 Thermostat

EVAPORATOR — BACK WALL

44-4050

CONSTRUCTION • AGRICULTURE • FORESTRY • TRUCKS • UNIVERSAL

The 44-4050 is a heavy duty plastic wall mounted Evaporator/Heater for small cabs. Three speed blower offering 290 CFM. Perfect for crane cabs or similar size applications.

**Not Sure What To Order?
We Can Help . . .**

**See the A/C System
Configuration Worksheet
on the last page of this catalog.**

<http://www.visionaire-inc.com>

866-838-2810



PART NO.

44-4050-1000 ACH	12VDC
44-4050-2000 ACH	24VDC
44-4050-1001 AC Only	12VDC
44-4050-2001 AC Only	24VDC

SHIPPING NOTICE

This unit can be shipped by UPS or LTL.

SPECIFICATIONS

Air Flow.....	290 CFM
Capacity.....	Cooling 18,500 BTU/hr.....Heating 35,000 BTU/hr
Current Draw	11 amps @ 12VDC5.5 amps @ 24VDC
Weight	28 LBS
Evaporator Coil	Copper Tubing Aluminum Fin
Dimensions.....	20.3" L x 17.3" W x 7.1" H
Motor	3 Speed Blower (low/med/high)

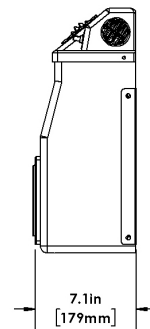
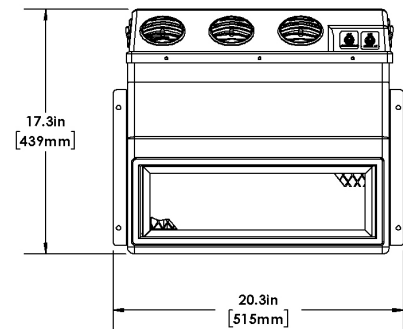

OPTIONS

- Remote Condenser
- Pressurizer Kit
- Refrigeration Hose Kit
- Heater Hose Kit

SERVICE PARTS

Part No.

10-20-4050	Evaporator Coil
10-30-4050	Heater Coil
14-20-0042	Blower Fan 12VDC
14-20-0043	Blower Fan 24VDC
12-11-1001	Expansion Valve

Part No.

15-10-1011	Return Air Filter
12-54-1001	Thermostat

EVAPORATOR — BACK WALL

44-4050M

CONSTRUCTION • AGRICULTURE • FORESTRY • TRUCKS • UNIVERSAL

The 44-4050 is a heavy duty metal wall mounted Evaporator/Heater for small cabs. Three speed blower offering 290 CFM. Perfect for crane cabs or similar size applications.

**Not Sure What To Order?
We Can Help . . .**

**See the A/C System
Configuration Worksheet
on the last page of this catalog.**

<http://www.visionaire-inc.com>
866-838-2810



PART NO.

44-4050-1100 ACH 12VDC
44-4050-2100 ACH 24VDC

SHIPPING NOTICE

This unit can be shipped by UPS or LTL.

SPECIFICATIONS

Air Flow.....290 CFM
Capacity.....Cooling 18,500 BTU/hr.....Heating 35,000 BTU/hr
Current Draw 11 amps @ 12VDC5.5 amps @ 24VDC
Weight30 LBS
Evaporator CoilCopper Tubing Aluminum Fin
Dimensions.....20.1" L x 20.1" W x 7.1" H
Motor3 Speed Blower (low/med/high)

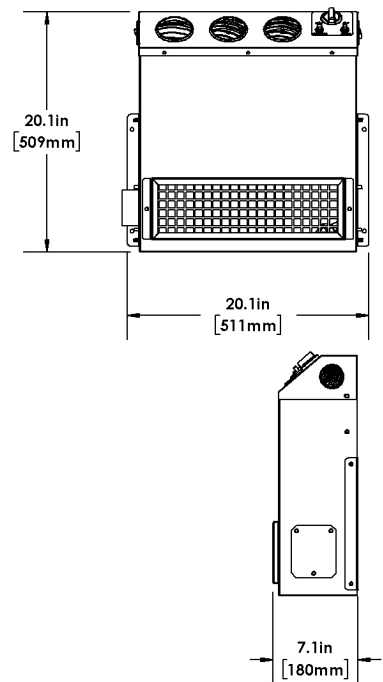

OPTIONS

- Remote Condenser
 - Pressurizer Kit
- Refrigeration Hose Kit
 - Heater Hose Kit

SERVICE PARTS

Part No.

10-20-4050 Evaporator Coil
10-30-4050 Heater Coil
14-20-0042..... Blower Fan 12VDC
14-20-0043..... Blower Fan 24VDC
12-11-1001 Expansion Valve

Part No.

15-10-1011 Return Air Filter
12-54-1001 Thermostat

EVAPORATOR — BACK WALL

44-4100

CONSTRUCTION • AGRICULTURE • FORESTRY • TRUCKS • UNIVERSAL

The 4100 compact evaporator is designed as an outside wall mount unit. A small operator cab with limited available space makes this unit ideal.

**Not Sure What To Order?
We Can Help . . .**

**See the A/C System
Configuration Worksheet
on the last page of this catalog.**

<http://www.visionaire-inc.com>

866-838-2810



PART NO.

44-4100-1001 AC Only 12VDC

44-4100-2001 AC Only 24VDC

SHIPPING NOTICE

Due to size and weight this unit must be shipped LTL.

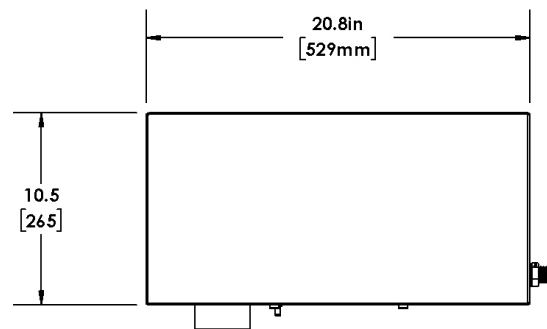

SPECIFICATIONS

Air Flow.....250 CFM
Capacity.....Cooling 16,000 BTU/hr
Current Draw8 amps @ 12VDC4 amps @ 24VDC
Weight25 LBS
Evaporator CoilCopper Tubing Aluminum Fin
Dimensions.....20.8" L x 10.5" W x 8.6" H
Motor3 Speed Blower (low/med/high)

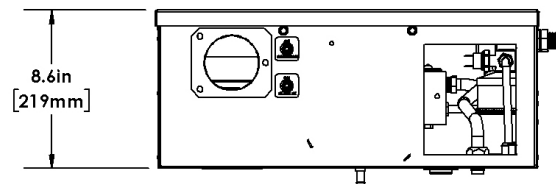

OPTIONS

- Remote Condenser
- Pressurizer Kit
- Refrigeration Hose Kit
- Heater Hose Kit

SERVICE PARTS

Part No.

10-20-4000 Evaporator Coil
12-11-1001 Expansion Valve
14-20-3013 Blower Fan 12VDC
14-20-3014 Blower Fan 24VDC
12-54-1001 Thermostat

Part No.

13-10-1000 Drier
15-10-0050 Air Filter

EVAPORATOR — BACK WALL

44-4145

CONSTRUCTION • AGRICULTURE • FORESTRY • TRUCKS • UNIVERSAL

The model 4145 features a steel chassis with plastic cover and is a popular wall-mounted evaporator for small to mid-size cabs. Offered as AC only or also offered as an AC + heat combo unit. This evaporator has a three speed blower offering 300 CFM. The 4145 is sized to fit between the seats in a day cab or as a wall mount in your off-highway cab.



**Not Sure What To Order?
We Can Help . . .**

**See the A/C System
Configuration Worksheet
on the last page of this catalog.**

<http://www.visionaire-inc.com>
866-838-2810

PART NO.

44-4145-1000 ACH	12VDC
44-4145-2000 ACH	24VDC
44-4145-1001 AC Only	12VDC
44-4145-2001 AC Only	24VDC

SHIPPING NOTICE

This unit can be shipped by UPS or LTL.

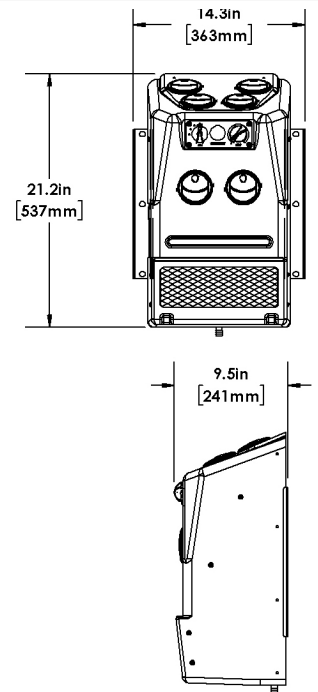

SPECIFICATIONS

Air Flow.....	300 CFM
Capacity.....	Cooling 20,000 BTU/hr.....Heating 20,700 BTU/hr
Current Draw	14.4 amps @ 12VDC7.2 amps @ 24VDC
Weight	18 LBS
Evaporator Coil	Copper Tubing Aluminum Fin
Dimensions.....	21.2" L x 14.3" W x 9.5" H
Motor	3 Speed Blower (low/med/high)

OPTIONS

- Remote Condenser
- Refrigeration Hose Kit
- Heater Hose Kit
- Mounting Feet

SERVICE PARTS

Part No.

10-40-4145.....	Evaporator Heater Coil
12-11-1001.....	Expansion Valve
14-20-0050.....	Blower Fan 12VDC
14-20-0051.....	Blower Fan 24VDC
15-10-1018.....	Return Air Filter

Part No.

12-54-1001.....	Thermostat ACH
12-54-2002.....	Thermostat AC Only
12-50-3002.....	Mode Switch
12-50-2001.....	Fan Speed Switch

EVAPORATOR — BACK WALL

44-4150

CONSTRUCTION • AGRICULTURE • FORESTRY • TRUCKS • UNIVERSAL

The 44-4150 is a heavy duty, powder coated steel evaporator that mounts on inside wall of cab. Perfect for medium size cabs. Pair with 3030 forced air condenser for optimum performance.

**Not Sure What To Order?
We Can Help . . .**

**See the A/C System
Configuration Worksheet
on the last page of this catalog.**

<http://www.visionaire-inc.com>

866-838-2810



PART NO.

44-4150-1000 ACH	12VDC
44-4150-2000 ACH	24VDC
44-4150-1001 AC Only	12VDC
44-4150-2001 AC Only	24VDC

SHIPPING NOTICE

Due to size and weight this unit must be shipped LTL.

SPECIFICATIONS

Air Flow.....	420 CFM
Capacity.....	Cooling 25,000 BTU/hr..... Heating 37,500 BTU/hr
Current Draw	30 amps @ 12VDC 15 amps @ 24VDC
Weight	50 LBS
Evaporator Coil	Copper Tubing Aluminum Fin
Dimensions.....	25.1" L x 23.5" W x 8.4" H
Motor	3 Speed Blower (low/med/high)

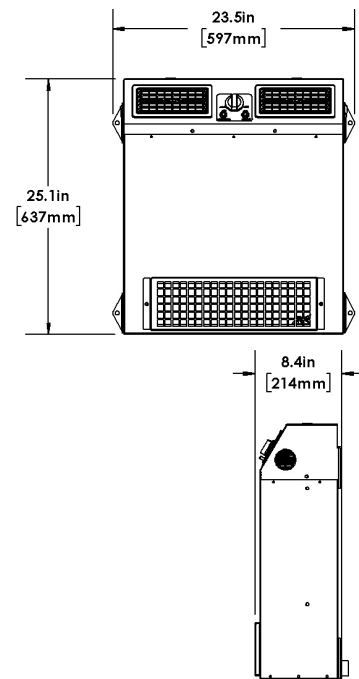

OPTIONS

- | | |
|--------------------|--------------------------|
| • Remote Condenser | • Refrigeration Hose Kit |
| • Pressurizer Kit | • Heater Hose Kit |

SERVICE PARTS

Part No.

10-20-4030.....	Evaporator Coil
10-30-4030.....	Heater Coil
14-20-0020.....	Blower Fan 12VDC
14-20-0021.....	Blower Fan 24VDC
12-11-1001.....	Expansion Valve

Part No.

15-10-1011.....	Return Air Filter
12-31-0001.....	Mechanical Water Valve
12-39-1052.....	Pull Cable
12-54-1001.....	Thermostat

EVAPORATOR — BACK WALL

44-4161

CONSTRUCTION • AGRICULTURE • FORESTRY • TRUCKS • UNIVERSAL

Model 4161 delivers the cooling or heating needed for those medium to large cab applications. This evaporator would require a remote mounted condenser and compressor. Available with optional plenum and duct kit to direct air wherever you need it to heat, cool, or defrost.

**Not Sure What To Order?
We Can Help . . .**

**See the A/C System
Configuration Worksheet
on the last page of this catalog.**

<http://www.visionaire-inc.com>

866-838-2810



PART NO.

44-4161-1000 ACH 12VDC

44-4161-2000 ACH 24VDC

SHIPPING NOTICE

Due to size and weight this unit must be shipped LTL.

SPECIFICATIONS

Air Flow.....500 CFM
 Capacity.....Cooling 36,000 BTU/hr.....Heating 30,000 BTU/hr
 Current Draw 18 amps @ 12VDC9 amps @ 24VDC
 Weight53 LBS
 Evaporator CoilCopper Tubing Aluminum Fin
 Dimensions.....27.5" L x 20.3" W x 11.1" H
 Motor3 Speed Blower (low/med/high)

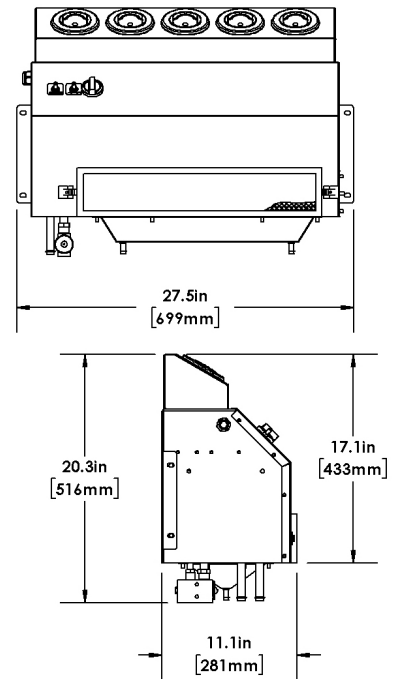

OPTIONS

- Remote Condenser
- Remote Compressor
- Refrigeration Hose Kit
- Heater Hose Kit

SERVICE PARTS

Part No.

- | | |
|--|-----------------------------------|
| 10-40-7160..... Evaporator and Heat Coil | 15-10-1007..... Return Air Filter |
| 12-11-1001..... Expansion Valve | 12-54-1001..... Thermostat |
| 14-20-0020..... Blower Fan 12VDC | |
| 14-20-0021..... Blower Fan 24VDC | |

EVAPORATOR — UNDER DASH — DUCTABLE

44-4220

UNIVERSAL

The 4220 is an under bunk or under dash unit that is ductable. Fits nicely in a sleeper cab where space is a concern, features AC+Heat.

**Not Sure What To Order?
We Can Help . . .**

**See the A/C System
Configuration Worksheet
on the last page of this catalog.**

<http://www.visionaire-inc.com>

866-838-2810

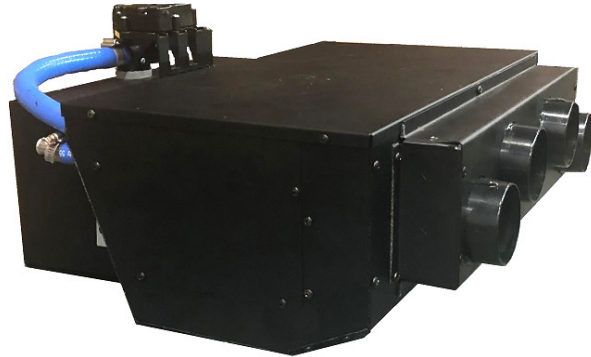

PART NO.

44-4220-1040 ACH..... 12VDC

44-4220-2040 ACH..... 24VDC

SHIPPING NOTICE

This unit can be shipped by UPS or LTL.

SPECIFICATIONS

Air Flow.....500 CFM
 Capacity.....Cooling 34,000 BTU/hr.....Heating 36,000 BTU/hr
 Current Draw22.5 amps @ 12VDC11.4 amps @ 24VDC
 Weight42 LBS
 Evaporator CoilCopper Tubing Aluminum Fin
 Dimensions.....23" L x 20.2" W x 8.2" H
 Motor3 Speed Blower (low/med/high)

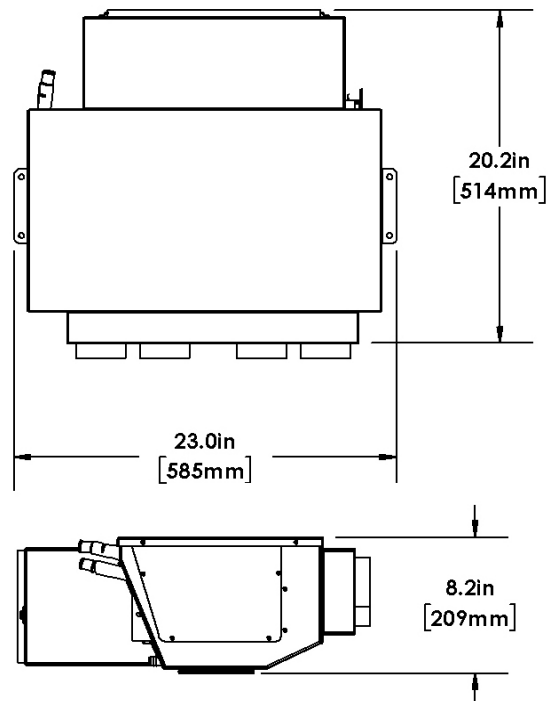

OPTIONS

- Duct Kit
- Refrigeration Hose Kit
- Heater Hose Kit

SERVICE PARTS

Part No.

10-20-4030Evaporator Coil
 10-30-4030Heater Coil
 12-11-1001Expansion Valve
 12-54-1001Thermostat

Part No.

14-20-0020Blower Fan 12VDC
 14-20-0021Blower Fan 24VDC



EVAPORATOR — BACK WALL

890091-12/24VDC - AC & Heat

CONSTRUCTION • ON & OFF-ROAD • FORESTRY

The 5400 is a heavy duty, powder coated black steel casing- wall mounted ductable HVAC unit. Perfect for small to medium size cabs.

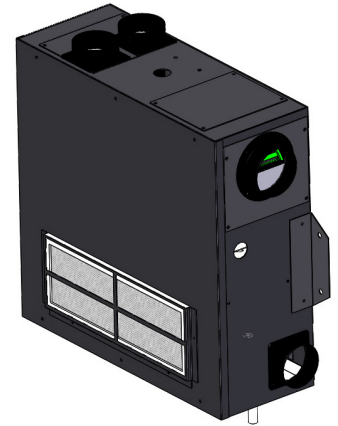

**Not Sure What To Order?
We Can Help . . .**

**See the A/C System
Configuration Worksheet
on the last page of this catalog.**

<https://atc.ca>

800-295-4156

PART NO.

890091 12/24VDC Base unit

890091 12VDC (11 Variants)

890091 24VDC (8 Variants)

Ductable Fresh Air Option Available

SHIPPING NOTICE

This unit can be shipped by UPS or LTL.

SPECIFICATIONS

Air Flow.....600 CFM
 Capacity.....Cooling 25,000 BTU/hr.....Heating 39,000 BTU/hr
 Current Draw21 amps @ 12VDC11 amps @ 24VDC
 Weight34 LBS
 CoilCopper Tubing Aluminum Fin- Evaporator and Heat Coils
 Dimensions..... 17.1875" L x 6.75" W x 20.6875" H
 Motor3 Speed Blower x 2 (low/med/high)

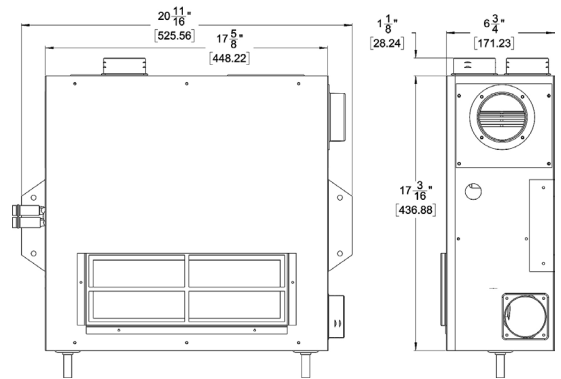

OPTIONS

- 810025 - Digital controller
- 820086-12/24VDC - Relay Box / Wiring Harness
- Optional Pressurizer Kit
- Engine Driven Compressor
- Refrigeration Hose Kit

SERVICE PARTS

Part No.

870109..... Evap Coil
 876056..... Heat Coil
 810086..... 3-Speed Blower 12VDC
 810091..... 3-Speed Blower 24VDC

Part No.

1600..... Expansion Valve
 N/A..... External Water Valve Option



EVAPORATOR — HEADLINER

890129-12/24VDC - AC & Heat

CONSTRUCTION • ON & OFF-ROAD • FORESTRY

The 890129-12/24VDC is a heavy duty, powder coated black steel casing-ceiling mounted HVAC unit. Perfect for small to medium size cabs.

**Not Sure What To Order?
We Can Help . . .**

**See the A/C System
Configuration Worksheet
on the last page of this catalog.**

<https://atc.ca>

800-295-4156

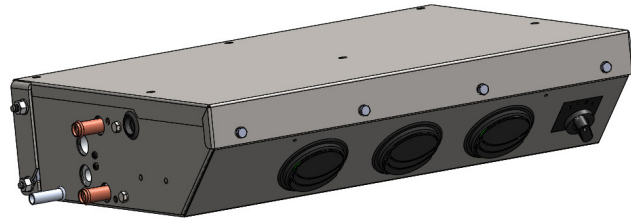

PART NO.

890129	12VDC-RH-AC Only
890129	12VDC-RHH-HVAC unit
890129	12VDC-LH-AC Only
890129	12VDC-LHH-HVAC unit
890129	24VDC-RH-AC Only
890129	24VDC-RHH-HVAC unit
890129	24VDC-LH-AC Only
890129	24VDC-LHH-HVAC unit
890129	12/24VDC

SHIPPING NOTICE

This unit can be shipped by UPS or LTL.

SPECIFICATIONS

Air Flow.....	350 CFM
Capacity.....	Cooling 19,000 BTU/hr.....Heating 25,000 BTU/hr
Current Draw	12 amps @ 12VDC6 amps @ 24VDC
Weight	25 LBS
Coil	Copper Tubing / Alum. Fin - Evaporator and Heat Coils
Dimensions.....	24.8125" L x 17.125" W x 5.25" H
Motor	3 Speed Blower (low/med/high)

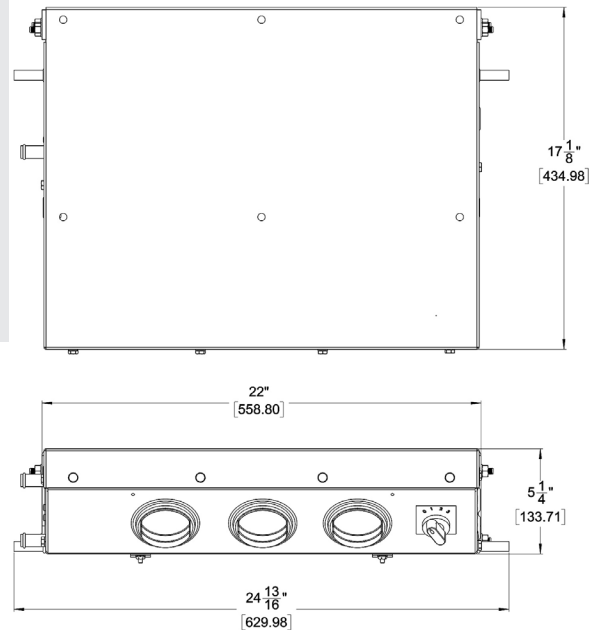

OPTIONS

- 810025 - Digital Controller
- 820086-12/24VDC - Relay Box / Wiring Harness
- Optional Pressurizer Kit
- Engine Driven Compressor
- Refrigeration Hose Kit

SERVICE PARTS

Part No.

870130.....	Evap Coil
870131.....	Evap Coil
876088.....	Heat Coil
810062.....	3-Speed Blower 12VDC

Part No.

810064.....	3-Speed Blower 24VDC
1600.....	Expansion Valve
N/A.....	External Water Valve Option



EVAPORATOR — HEADLINER

890151-12/24VDC - AC & Heat (LH connection)
890152-12/24VDC - AC & Heat (RH connection)

CONSTRUCTION • ON & OFF-ROAD • FORESTERY

The 890151-12/24 VDC / 890152-12/24VDC are heavy duty, low profile ceiling/Headliner mounted HVAC unit, powder coated black steel hinged casing -perfect for small to medium size cabs.

**Not Sure What To Order?
We Can Help . . .**

**See the A/C System
Configuration Worksheet
on the last page of this catalog.**

<https://atc.ca>

800-295-4156

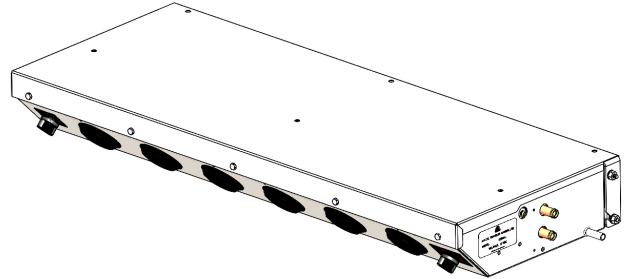

PART NO.

890151	12VDC-LH-AC Only
890151	12VDC-LHH-HVAC unit
890152	12VDC-RH-AC Only
890152	12VDC-RHH-HVAC unit
890151	24VDC-LH-AC Only
890151	24VDC-LHH-HVAC unit
890152	24VDC-RH-AC Only
890152	24VDC-RHH-HVAC unit

SHIPPING NOTICE

This unit can be shipped by UPS or LTL.

SPECIFICATIONS

Air Flow.....	700 CFM
Capacity.....	Cooling 35,000 BTU/hr.....Heating 45,000 BTU/hr
Current Draw	24 amps @ 12VDC 12 amps @ 24VDC
Weight	50 LBS
Coil	Copper Tubing / Alum. Fin - Evaporator and Heat Coils
Dimensions.....	17.2" L x 46.4" W x 5.3" H
Motor	3 Speed Blower x 2 (low/med/high)

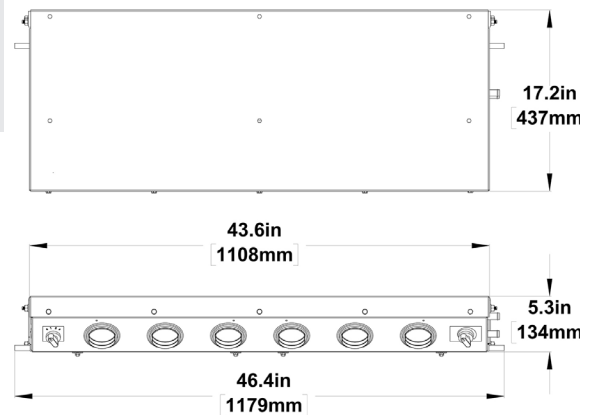

OPTIONS

- 810025 - Digital Controller
- 820086-12/24VDC - Relay Box / Wiring Harness
- Engine Driven Compressor
- Refrigeration Hose Kit

SERVICE PARTS

Part No.

870160.....	Evap Coil
870161.....	Evap Coil
876089.....	Heat Coil
810062.....	3-Speed Blower 12VDC

Part No.

810064.....	3-Speed Blower 24VDC
1600.....	Expansion Valve
N/A.....	External Water Valve Option

EVAPORATOR — WALL MOUNT

890121-12/24VDC

CONSTRUCTION • ON & OFF-ROAD • FORESTERY

The 5410 is a heavy duty, powder coated black steel casing- wall mounted compact HVAC unit. Perfect for small sized cabs.

**Not Sure What To Order?
We Can Help . . .**

**See the A/C System
Configuration Worksheet
on the last page of this catalog.**

<https://atc.ca>

800-295-4156

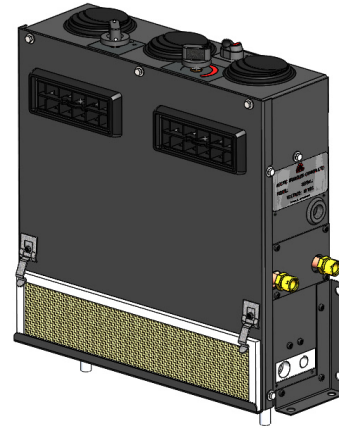

PART NO.

890121 12VDC
890121 12/24VDC

SHIPPING NOTICE

This unit can be shipped by UPS or LTL.

SPECIFICATIONS

Air Flow.....350 CFM
Capacity.....Cooling 16,800 BTU/hr.....Heating 22,000 BTU/hr
Current Draw 12.5 amps @ 12VDC7 amps @ 24VDC
Weight25 LBS
CoilCopper Tubing / Alum. Fin - Evaporator and Heat Coils
Dimensions..... 15.68.75" L x 15.375" W x 5.25" H
Motor3 Speed Blower (low/med/high)

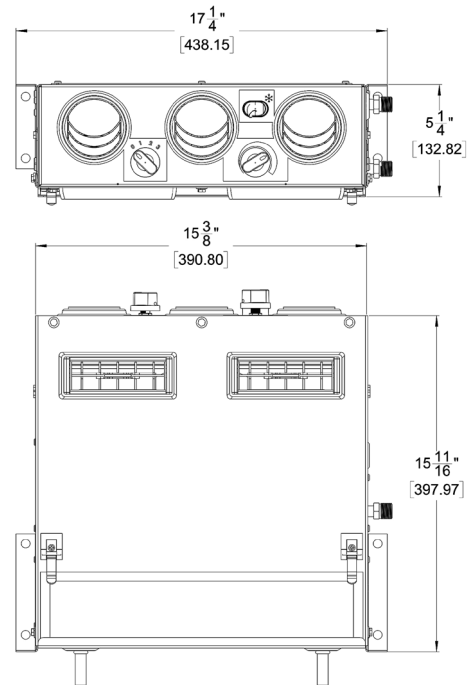

OPTIONS

- 810025 - Digital Controller
- 820086-12/24VDC - Relay Box / Wiring Harness
- Optional Pressurizer Kit
- Engine Driven Compressor
- Refrigeration Hose Kit

SERVICE PARTS

Part No.

870124..... Combo Coil (Cooling/ Heating)
810062..... 3-Speed Blower 12VDC
810064..... 3-Speed Blower 24VDC

Part No.

1600..... Expansion Valve
26-0666 2-Way Water Valve



EVAPORATOR — FLOOR MOUNT

890119-12/24VDC

CONSTRUCTION • ON & OFF-ROAD • FORESTERY

This HVAC is a heavy duty, powder coated black steel casing- under-seat ductable unit. Perfect for small to medium sized cabs.

Not Sure What To Order?
We Can Help . . .

See the A/C System
Configuration Worksheet
on the last page of this catalog.

<https://atc.ca>

800-295-4156

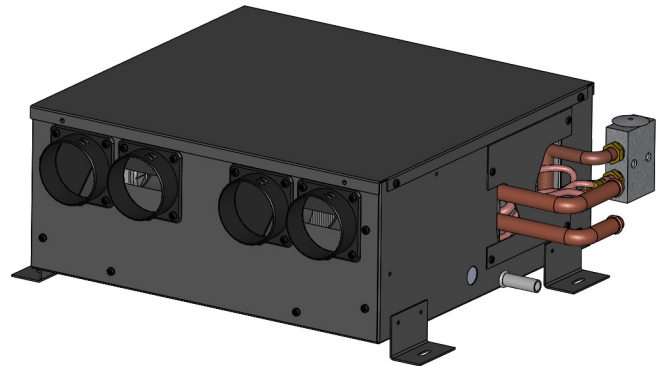

PART NO.

890119	12/24VDC
890119	12VDC
890119	24V-L (Louver Plate)

SHIPPING NOTICE

This unit can be shipped by UPS or LTL.

SPECIFICATIONS

Air Flow.....	450 CFM
Capacity.....	Cooling 22,000 BTU/hr.....Heating 32,500 BTU/hr
Current Draw	15 amps @ 12VDC8 amps @ 24VDC
Weight	25 LBS
Coil	Copper Tubing Aluminum Fin- Evaporator and Heat Coils
Dimensions.....	15.375" L x 16.1875" W x 7.375" H
Motor	3 Speed Blower (low/med/high)

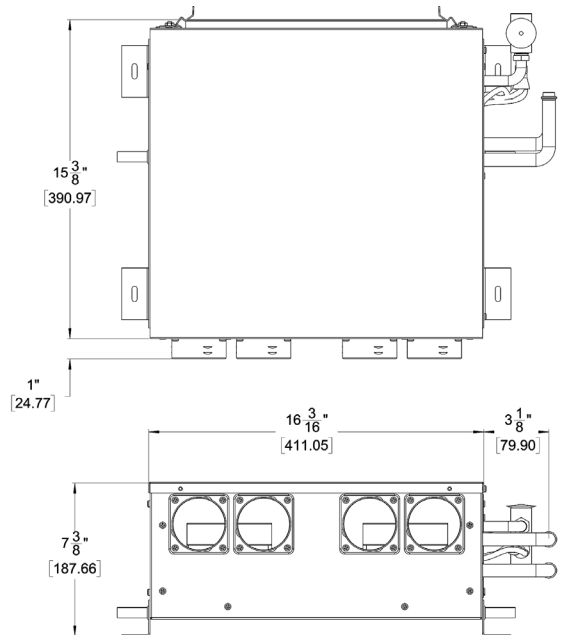

OPTIONS

- 810025 - Digital Controller
- 820086-12/24VDC - Relay box / Wiring Harness
- Optional Pressurizer Kit
- Engine Driven Compressor
- Refrigeration Hose Kit

SERVICE PARTS

Part No.

870121.....	Evap Coil
876065.....	Heat Coil
810067.....	3-Speed Blower 12VDC
3237.....	3-Speed Blower 24VDC

Part No.

1600.....	Expansion Valve
N/A.....	External Water Valve Option

EVAPORATOR — CEILING MOUNT

520-12VDC-SALON
520-24VDC-SALON

UNIVERSAL

Steel compact ceiling mount evaporator with 2 blowers and 2 directional louvers.

**Not Sure What To Order?
We Can Help . . .**

**See the A/C System
Configuration Worksheet
on the last page of this catalog.**

<https://www.hammondac.com>
800-267-2665

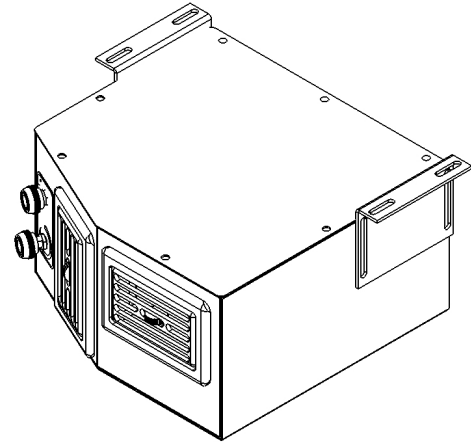

PART NO.

520-12VDC-SALON 12VDC
520-24VDC-SALON 24VDC

SHIPPING NOTICE

This unit can be shipped by UPS or LTL.

SPECIFICATIONS

Air Flow.....612 CFM
Capacity.....Cooling 18,500 BTU/hr
Current Draw 10 amps @ 12VDC5 amps @ 24VDC
Weight20 LBS
CoilAluminum
Dimensions.....14.18" L x 14.88" W x 6.61" H
Motor3" Speed Scroll Blower

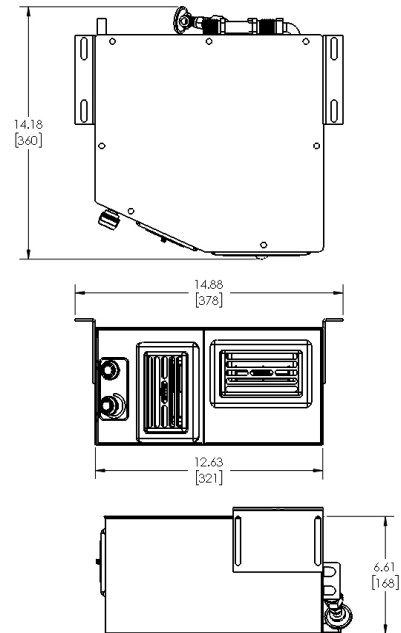

OPTIONS • N/A

SERVICE PARTS

Part No.	
411-364	Evaporator Coil
514-410	Expansion Valve
401-864	Blower, 12VDC
401-854-24	Blower, 24VDC
413-203	Thermostat 18"

Part No.	
411-110	Louver
412-102	4 Position Switch
411-058	Fan Control Knob
412-132	Solenoid Valve 24VDC
412-131	Solenoid Valve 12VDC

EVAPORATOR — CEILING MOUNT

HA-9750-12
HA-9750-24

UNIVERSAL

Steel ceiling mount heat/cool unit with 3 directional louvers.

**Not Sure What To Order?
We Can Help . . .**

**See the A/C System
Configuration Worksheet
on the last page of this catalog.**

<https://www.hammondac.com>
800-267-2665

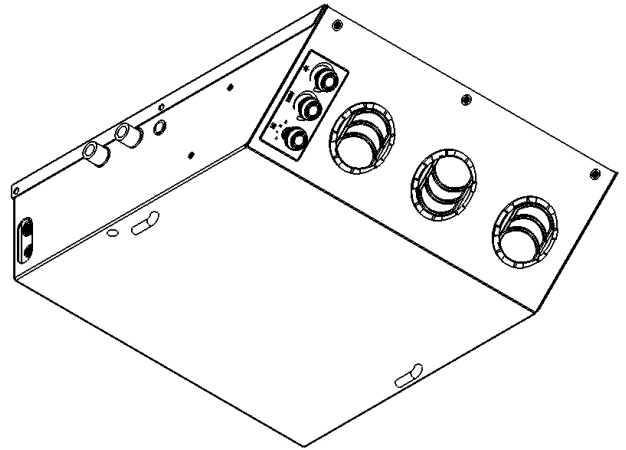

PART NO.

HA-9750-12 12VDC
HA-9750-24 24VDC

SHIPPING NOTICE

This unit can be shipped by UPS
or LTL.

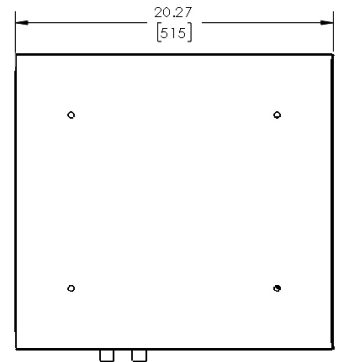

SPECIFICATIONS

Air Flow..... 378 CFM
Capacity..... Cooling 19,000 BTU/hr..... Heating 26,000 BTU/hr
Current Draw 12 amps @ 12VDC 6 amps @ 24VDC
Weight 25 LBS
Coil Copper Tubing Aluminum Fin
Dimensions..... 20.27" L x 19.62" W x 5.77" H
Motor Low / Med / High 3 Speed Blower

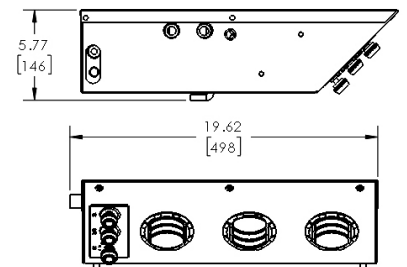

OPTIONS • N/A

SERVICE PARTS

Part No.

411-146 Evaporator Coil
411-475-H Heater Core
514-412 Expansion Valve
401-850 Blower, 12VDC
401-851 Blower, 24VDC

Part No.

413-203 Thermostat 18"
411-842 Louver, 3.25"
412-102 4 Position Switch
412-983A Pot Switch Assembly
411-055 Knob, Plain with line

EVAPORATOR — CEILING MOUNT

411-580-E35PL-12
411-580-E35PL-24

UNIVERSAL

Steel small ceiling mount unit with directional louvers, A/C only.

**Not Sure What To Order?
We Can Help . . .**

**See the A/C System
Configuration Worksheet
on the last page of this catalog.**

<https://www.hammondac.com>
800-267-2665

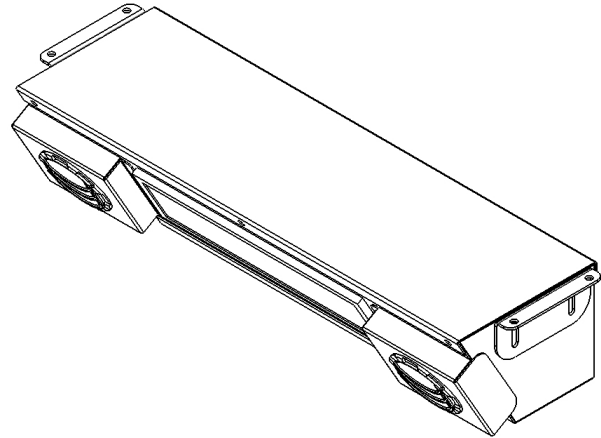

PART NO.

411-580-E35PL-12 12VDC
411-580-E35PL-24 24VDC

SHIPPING NOTICE

This unit can be shipped by UPS or LTL.

SPECIFICATIONS

Air Flow.....612 CFM
Capacity.....15,000 BTU
Current Draw20 amps @ 12VDC10 amps @ 24VDC
Weight20 LBS
CoilCopper Tubing Aluminum Fin
Dimensions.....25.21" L x 8.65" W x 5.31" H
MotorLow / Med / High 3 Speed Scroll Blower

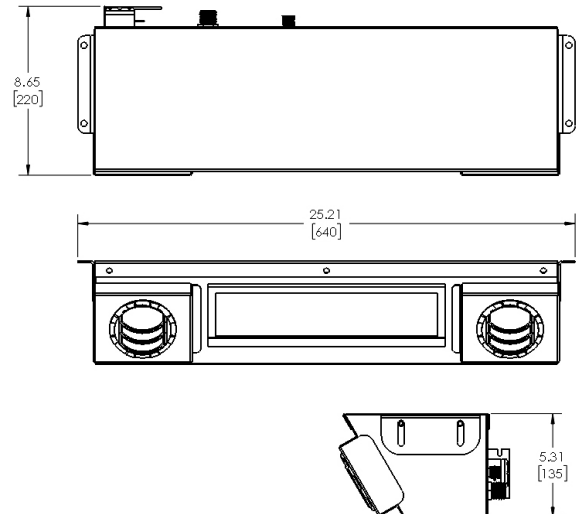

OPTIONS • N/A

SERVICE PARTS

Part No.
411-580-E35PL.....Evaporator Coil
514-410Expansion Valve
401-854-24.....Blower, 24VDC
401-864Blower, 12VDC
413-204Thermostat 24"

Part No.
411-867Louver
435-012Filter
412-1024 Position Switch
411-063Fan Control Knob - Soft

EVAPORATOR — EXTERNAL WALL MOUNT

520-NGC-100

UNIVERSAL

Steel wall mount dual blower evaporator with 4 directional louvers, A/C only.

**Not Sure What To Order?
We Can Help . . .**

**See the A/C System
Configuration Worksheet
on the last page of this catalog.**

<https://www.hammondac.com>
800-267-2665

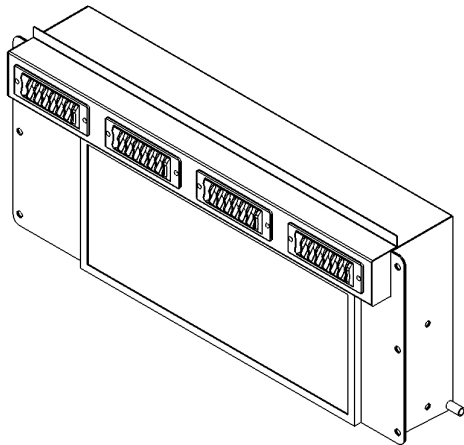

PART NO.

520-NGC-100..... 12VDC

SHIPPING NOTICE

This unit can be shipped by UPS or LTL.

SPECIFICATIONS

- Air Flow.....896 CFM
- Capacity.....Cooling 30,000 BTU/hr
- Current Draw32 amps @ 12VDC
- Weight40 LBS
- CoilCopper Tubing Aluminum Fin
- Dimensions.....30" L x 6.66" W x 13.5" H
- MotorLow / Med / High 3 Speed Scroll Blowers

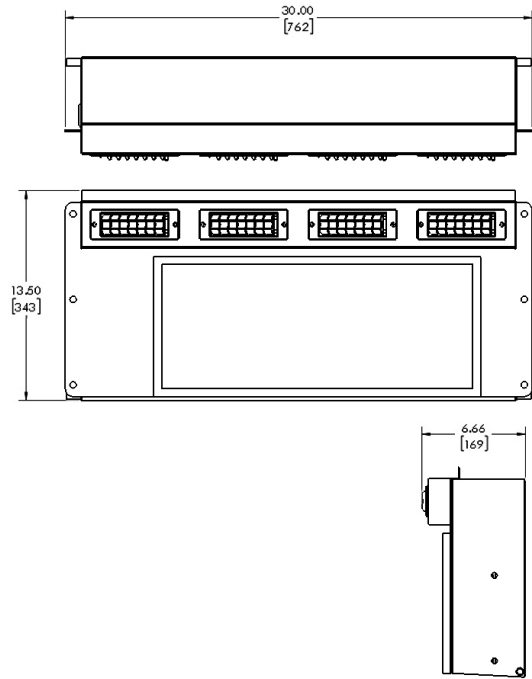

- OPTIONS**
- 24VDC Available upon request
 - 1200 CFM Optional

- Flex Ducting
- Louvers

SERVICE PARTS

- Part No.**
- 411-966-NGC..... Evaporator Coil
 - 514-412 Expansion Valve
 - 401-463 Blower, 12VDC
 - 413-204 Thermostat 24"

- Part No.**
- 411-846 Louver
 - 435-019 Filter

EVAPORATOR — FLOOR MOUNT

HA-320-7-12

UNIVERSAL

Steel floor mounted heat/cool unit with hose adapters for ducting.

**Not Sure What To Order?
We Can Help . . .**

**See the A/C System
Configuration Worksheet
on the last page of this catalog.**

<https://www.hammondac.com>

800-267-2665

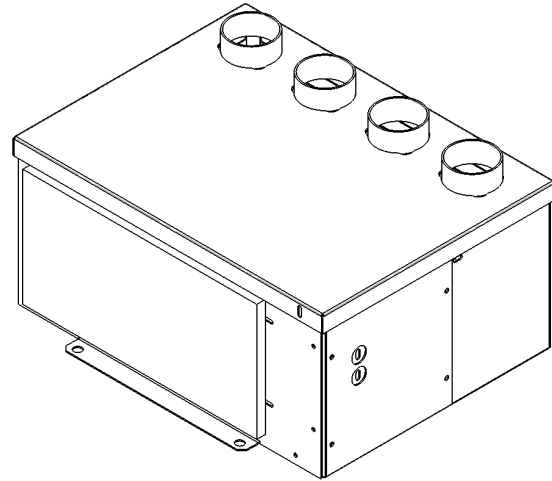

PART NO.

HA-320-7-1212VDC

SHIPPING NOTICE

This unit can be shipped by UPS or LTL.

SPECIFICATIONS

Air Flow.....637 CFM
 Capacity.....Cooling 23,000 BTU/hr.....Heating 31,000 BTU/hr
 Current Draw25 amps @ 12VDC
 Weight25 LBS
 CoilCopper Tubing Aluminum Fin
 Dimensions.....17.21" L x 14.74" W x 10" H
 MotorLow / Med / High 3 Speed Blower

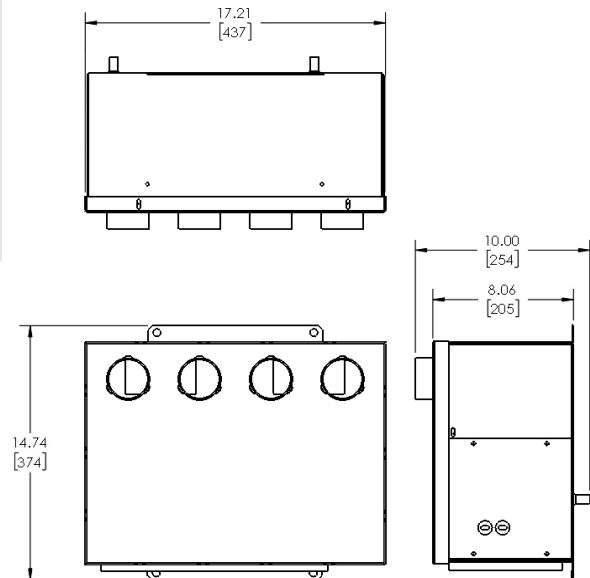

OPTIONS

- 24V Available upon request
- Standoff Brackets Available
- Flex Ducting
- Louvers

SERVICE PARTS

Part No.

411-929Evaporator Coil
 411-930Heater Coil
 514-412Expansion Valve
 401-440Blower, 12VDC

Part No.

413-204Thermostat 24"
 419-816Hose Adapter
 435-055-1Filter
 314-RT914-100.....Wiring Harness

EVAPORATOR — FLOOR MOUNT — BETWEEN THE SEATS

411-300-T30

UNIVERSAL • FORKLIFT

Steel compact floor mount or between the seats heat/cool unit with 4 direction a louvers.

**Not Sure What To Order?
We Can Help . . .**

**See the A/C System
Configuration Worksheet
on the last page of this catalog.**

<https://www.hammondac.com>

800-267-2665

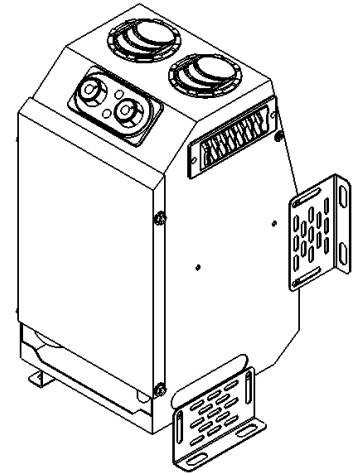

PART NO.

411-300-T30..... 12VDC

SHIPPING NOTICE

This unit can be shipped by UPS or LTL.

SPECIFICATIONS

Air Flow.....290 CFM
 Capacity.....Cooling 15,000 BTU/hr.....Heating 18,000 BTU/hr
 Current Draw 15 amps @ 12VDC7.5 amps @ 24VDC
 Weight35 LBS
 CoilAluminum
 Dimensions..... 10.69" L x 9.35" W x 17" H
 MotorLow / Med / High 3 Speed Scroll Blower

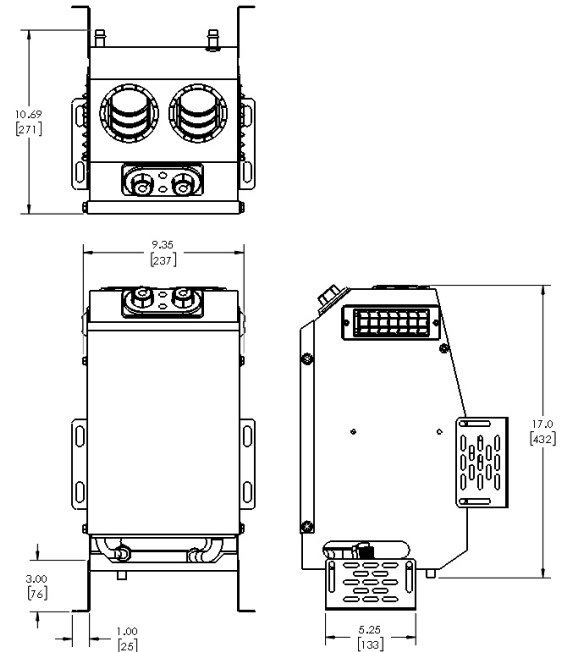

OPTIONS • 24V Available upon request

SERVICE PARTS

Part No.

411-300Evaporator Coil
 TBD.....Heater Coil
 514-410Expansion Valve
 401-856Blower, 12VDC
 413-205A.....Thermostat 48" wrapped
 411-842Louver

Part No.

411-846Louver
 412-1024 Position Switch
 412-983A.....Pot Switch Assembly
 412-172Resistor, 12VDC
 411-055Knob, Plain with line

EVAPORATOR — EXTERNAL WALL MOUNT

901-12
901-24

UNIVERSAL

Steel external wall mounted heat/cool unit with louver bezel plate and 4 directional louvers.

**Not Sure What To Order?
We Can Help . . .**

**See the A/C System
Configuration Worksheet
on the last page of this catalog.**

<https://www.hammondac.com>
800-267-2665

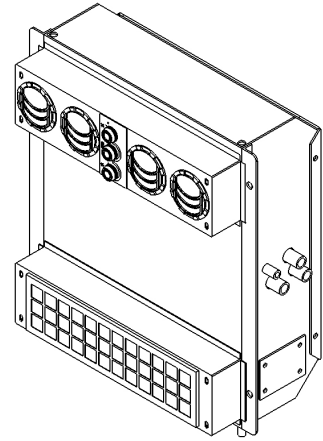

PART NO.

901-12 12VDC
901-24 24VDC

SHIPPING NOTICE

This unit can be shipped by UPS or LTL.

SPECIFICATIONS

Air Flow.....590 CFM
Capacity.....Cooling 24,000 BTU/hr.....Heating 30,000 BTU/hr
Current Draw30 amps @ 12VDC15 amps @ 24VDC
Weight62 LBS
CoilCopper Tubing Aluminum Fin
Dimensions.....20.00" L x 10.06" W x 22.38" H
MotorLow / Med / High 3 Speed Scroll Blower

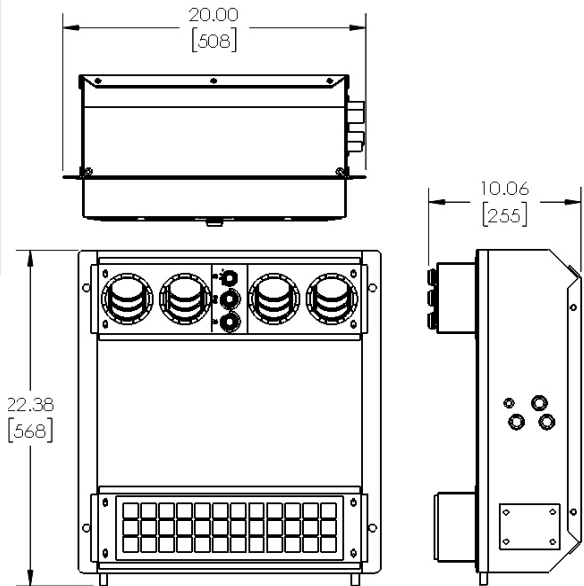

- OPTIONS**
- Flex Ducting
 - Louvers

SERVICE PARTS

Part No.

411-002 Evaporator/Heater Coil
514-408 Expansion Valve
401-856-24 Blower, 24VDC
401-856 Blower, 12VDC
413-205 Thermostat 48"

Part No.

411-861 Louver
435-014 Filter
412-102 4 Position Switch
412-123 Toggle Switch On/Off/On
412-128 Solenoid Valve 24VDC

EVAPORATOR — WALL MOUNT

901-000-A-100

MARINE

Aluminum heat/cool evaporator box with drier and heater control valve.

**Not Sure What To Order?
We Can Help . . .**

**See the A/C System
Configuration Worksheet
on the last page of this catalog.**

<https://www.hammondac.com>
800-267-2665

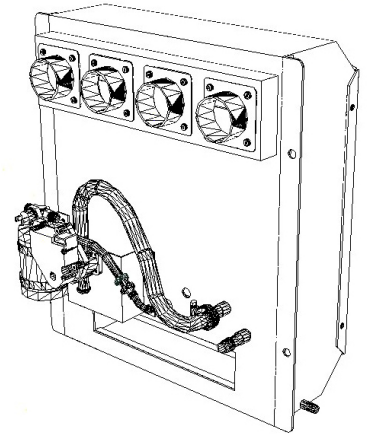

PART NO.

901-000-A-10024VDC

SHIPPING NOTICE

This unit can be shipped by UPS
or LTL.

SPECIFICATIONS

Air Flow.....590 CFM
Capacity.....Cooling 24,000 BTU/hr.....Heating 30,000 BTU/hr
Current Draw30 amps @ 12VDC15 amps @ 24VDC
Weight48 LBS
CoilCopper Tubing Aluminum Fin
Dimensions.....20.00" L x 12.25" W x 21.5" H
MotorLow / Med / High 3 Speed Scroll Blower

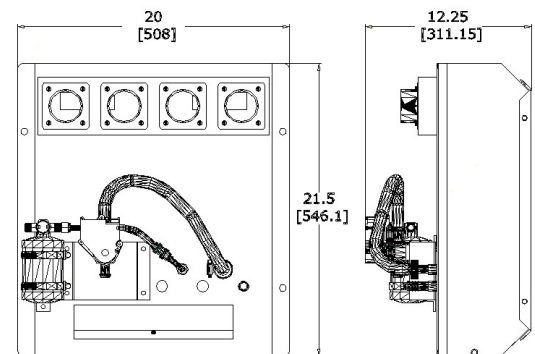

OPTIONS

- 12VDC Available upon request
- Customizable
- 3 blowers

- A/C only
- Flex Ducting
- Louvers

SERVICE PARTS

Part No.

411-002A Evaporator/Heater Coil
514-410 Expansion Valve
401-856-24 Blower, 24VDC
413-205P Thermostat

Part No.

419-843 Hose Adapter
523-556-7 Drier Assembly
412-153 Binary Switch
413-229N Marine Switch Panel

EVAPORATOR — WALL MOUNT

520-12VDC-210SP

UNIVERSAL • TRUCKS

Steel small single blower A/C only evaporator assembly.

**Not Sure What To Order?
We Can Help . . .**

**See the A/C System
Configuration Worksheet
on the last page of this catalog.**

<https://www.hammondac.com>

800-267-2665

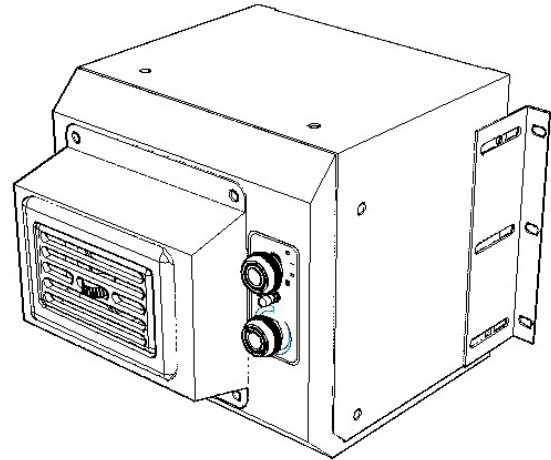

PART NO.

520-12VDC-210SP12VDC

SHIPPING NOTICE

This unit can be shipped by UPS or LTL.

SPECIFICATIONS

Air Flow.....306 CFM
Capacity.....14,000 BTU
Current Draw10 amps @ 12VDC5 amps @ 24VDC
Weight13 LBS
CoilAluminum
Dimensions.....12.2" L x 11.2" W x 9.1" H
MotorLow / Med / High 3 Speed Scroll Blower

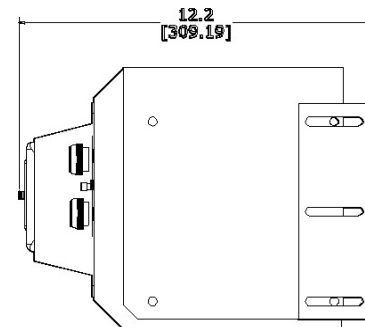
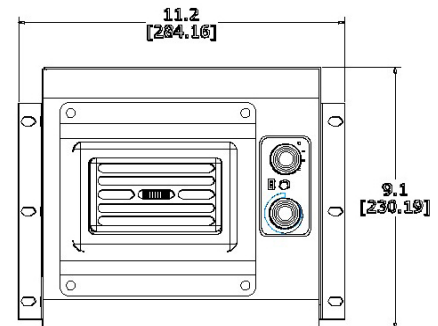

OPTIONS • 24VDC Available upon request

SERVICE PARTS

Part No.

411-300-100.....Evaporator Coil Assembly
514-410Expansion Valve
401-864A.....Blower Assembly, 12VDC
111-051Rotary Thermostat
411-110Louver

Part No.

412-1024 Position Switch
411-064Snowflake Knob
411-058Fan Control Knob
314-004-154.....Main Wiring Harness
318-002-241Wiring Harness

EVAPORATOR — WALL MOUNT

520-12VDC-210DC

UNIVERSAL • TRUCKS

Steel small single blower A/C only evaporator assembly with standoff bracket and directional louver plate.

**Not Sure What To Order?
We Can Help . . .**

**See the A/C System
Configuration Worksheet
on the last page of this catalog.**

<https://www.hammondac.com>

800-267-2665

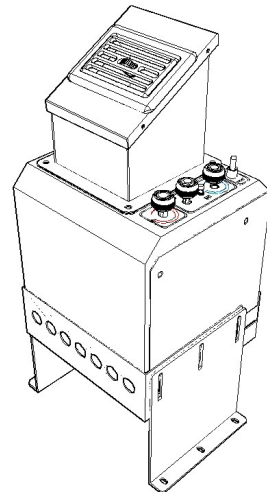

PART NO.

520-12VDC-210DC 12VDC

SHIPPING NOTICE

This unit can be shipped by UPS or LTL.

SPECIFICATIONS

Air Flow.....306 CFM
Capacity.....14,000 BTU
Current Draw 10 amps @ 12VDC5 amps @ 24VDC
Weight 15 LBS
CoilAluminum
Dimensions..... 11.9" L x 9.1" W x 23.1" H
MotorLow / Med / High 3 Speed Scroll Blower

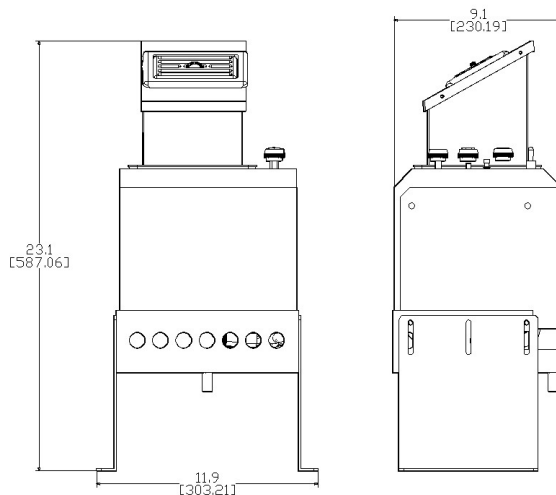

OPTIONS • 24V Available upon request

SERVICE PARTS

Part No.

411-300-100.....Evaporator Coil Assembly
514-410Expansion Valve
401-864A.....Blower Assembly, 12VDC
111-051Rotary Thermostat
411-110Louver

Part No.

412-102 4 Position Switch
411-064Snowflake Knob
411-058Fan Control Knob
314-004-154..... Main Wiring Harness
318-002-241 Wiring Harness

HEATER **42-2200**
UNIVERSAL

The 2200 Is a rugged, low profile heater perfect for small to mid size cabs. Resistor mounted on heater allows up to three speeds.

**Not Sure What To Order?
 We Can Help . . .**

**See the A/C System
 Configuration Worksheet
 on the last page of this catalog.**

<http://www.visionaire-inc.com>
866-838-2810



<u>PART NO.</u>	<u>SHIPPING NOTICE</u>
42-2200-1111 Rear Exit 12VDC	This unit can be shipped by UPS.
42-2200-2111 Rear Exit 24VDC	
42-2200-1112 Floor Exit 12VDC	
42-2200-2112 Floor Exit 24VDC	

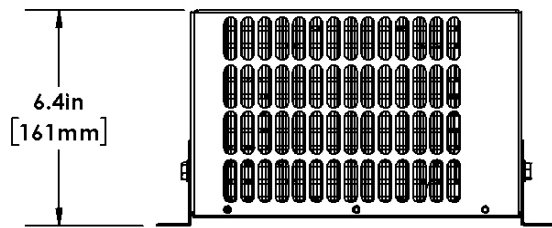
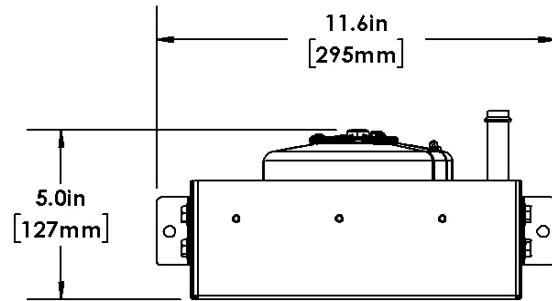

SPECIFICATIONS

Air Flow.....200 CFM
 Capacity.....16,000 BTU/hr
 Current Draw4 amps @ 12VDC2 amps @ 24VDC
 Weight7 LBS
 Dimensions.....11.6" L x 5" W x 6.4" H
 Motor5" Fan

- OPTIONS**
- | | |
|-----------------------|-------------------|
| • 3 Speed Switch/Knob | • Booster Pump |
| • Heater Hose Kit | • Water Valve Kit |

SERVICE PARTS

<u>Part No.</u>	<u>Part No.</u>
10-30-2200R	Heater Coil Rear
10-30-2200B.....	Heater Coil Floor
14-10-0510.....	Fan 12VDC
14-10-0520.....	Fan 24VDC
12-55-0010.....	Resistor

HEATER — DUCTABLE — UNDER DASH
42-2205
UNIVERSAL

The 2205 ductable coolant cab heater warms the cab while defrosting the windows. This heater can be mounted in any position, either by utilizing the leg brackets or mounting straight to the frame. Hose connections out the back or out the bottom will allow for custom install. Various duct parts available to suit any application.

**Not Sure What To Order?
We Can Help . . .**

**See the A/C System
Configuration Worksheet
on the last page of this catalog.**

<http://www.visionaire-inc.com>
866-838-2810

PART NO.

42-2205-1111 Rear Exit 12VDC
42-2205-2111 Rear Exit 24VDC
42-2205-1112 Floor Exit .. 12VDC
42-2205-2112 Floor Exit ... 24VDC

SHIPPING NOTICE

This unit can be shipped by UPS.

SPECIFICATIONS

Air Flow.....220 CFM
 Capacity..... 16,000 BTU/hr
 Current Draw4 amps @ 12VDC2 amps @ 24VDC
 Weight7 LBS
 Dimensions.....11.6" L x 7.2" W x 6.7" H
 MotorSingle Blower

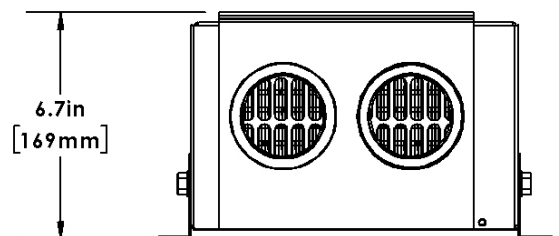
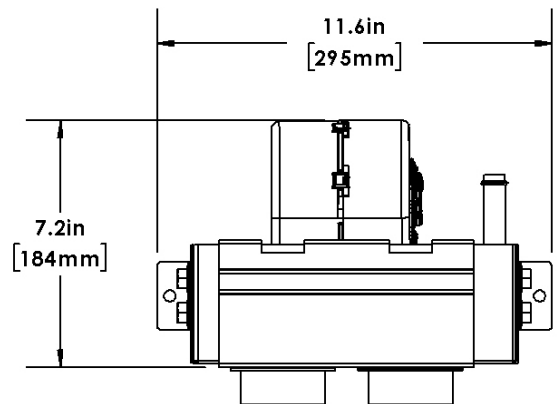
OPTIONS

- 3 Speed Switch/Knob
- Heater Hose Kit
- Duct Kit
- Water Valve Kit

SERVICE PARTS
Part No.

10-30-2200R Heater Coil Rear
 10-30-2200B..... Heater Coil Floor
 14-20-0047 Blower Fan 12VDC
 14-20-0048..... Blower Fan 24VDC

HEATER 42-2210

UNIVERSAL

The 2210 is a rugged, low profile high output heater perfect for large cabs and small cargo areas. resistor mounted on heater allows up to three speeds.

**Not Sure What To Order?
We Can Help . . .**

**See the A/C System
Configuration Worksheet
on the last page of this catalog.**

<http://www.visionaire-inc.com>
866-838-2810

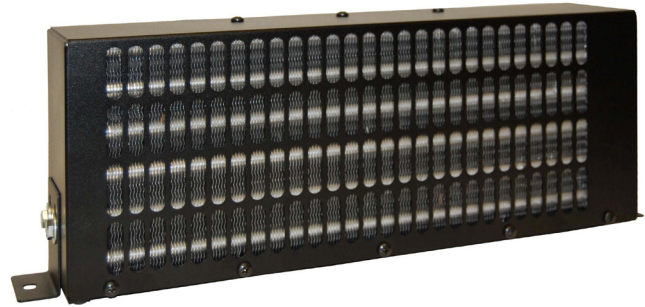

PART NO.

- 42-2210-1111 Rear Exit**..... 12VDC
- 42-2210-2111 Rear Exit**..... 24VDC
- 42-2210-1112 Floor Exit**..... 12VDC
- 42-2210-2112 Floor Exit**..... 24VDC

SHIPPING NOTICE

This unit can be shipped by UPS.

SPECIFICATIONS

- Air Flow.....400 CFM
- Capacity.....30,000 BTU/hr
- Current Draw7.4 amps @ 12VDC3.7 amps @ 24VDC
- Weight 10 LBS
- Dimensions..... 18.4" L x 4.7" W x 6.4" H
- Motor5" Fans

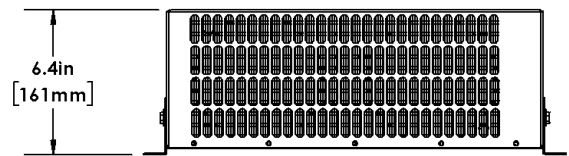
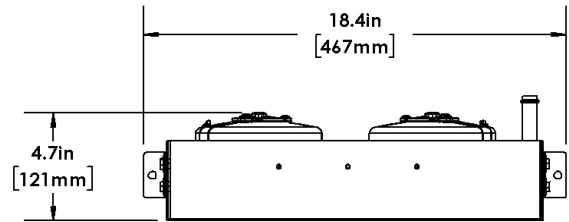

OPTIONS

- 3 Speed Switch/Knob
- Coolant Booster Pump
- Heater Hose Kit
- Water Valve Kit

SERVICE PARTS

Part No.

- 10-30-2210RHeater Coil Rear
- 10-30-2210B.....Heater Coil Floor
- 14-10-0510Fan 12VDC
- 14-10-0520Fan 24VDC
- 12-55-0010Resistor

HEATER — DUCTABLE — UNDER DASH

42-2215

UNIVERSAL

The 2215 is a rugged, low profile high output heater perfect for large cabs and small cargo areas. Ductable to bring heat direct to windshield/window. Resistor mounted on heater allows up to three speeds.

**Not Sure What To Order?
We Can Help . . .**

**See the A/C System
Configuration Worksheet
on the last page of this catalog.**

<http://www.visionaire-inc.com>
866-838-2810



PART NO.

- 42-2215-1111 Rear Exit** 12VDC
- 42-2215-2111 Rear Exit** 24VDC
- 42-2215-1112 Floor Exit** ... 12VDC
- 42-2215-2112 Floor Exit** ... 24VDC

SHIPPING NOTICE

This unit can be shipped by UPS.

SPECIFICATIONS

- Air Flow..... 430 CFM
- Capacity..... 30,000 BTU/hr
- Current Draw 7.4 amps @ 12VDC 3.7 amps @ 24VDC
- Weight 13 LBS
- Dimensions..... 18.4" L x 8.3" W x 6.7" H
- Motor Dual Blower

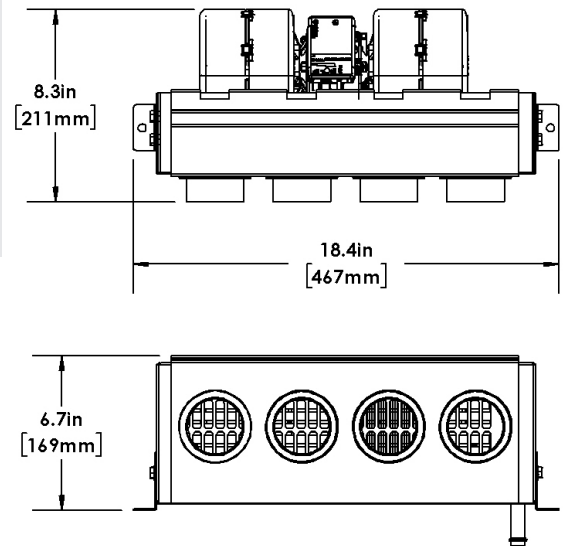

OPTIONS

- 3 Speed Switch/Knob
- Duct Kit
- Heater Hose Kit
- Water Valve Kit

SERVICE PARTS

Part No.

- 10-30-2210R Heater Coil Rear
- 10-30-2210B..... Heater Coil Floor
- 14-20-0042..... Blower Fan 12VDC
- 14-20-0043..... Blower Fan 24VDC

HEATER 42-2900

UNIVERSAL

When heat is needed and engine coolant is not readily available the 2900 Self-Contained Diesel Fired Coolant Heater is the answer. This heater box includes a diesel fired heater, fuel pump, fuel filter, coolant reservoir, and all hardware needed for complete install. An optional fuel tank is available. Perfect for crane cabs, where running coolant lines through the swivel is not an option.

**Not Sure What To Order?
We Can Help . . .**

**See the A/C System
Configuration Worksheet
on the last page of this catalog.**

<http://www.visionaire-inc.com>

866-838-2810



PART NO.	SHIPPING NOTICE
42-2900-1400 12VDC	This unit can be shipped by UPS or LTL.

SPECIFICATIONS

Air Flow..... N/A
 Capacity..... 8,600 - 17,000 BTU/hr
 Current Draw 3.8 amps @ 12VDC 1.9 amps @ 24VDC
 Weight 25 LBS
 Dimensions..... 14.3" L x 12" W x 12.1" H

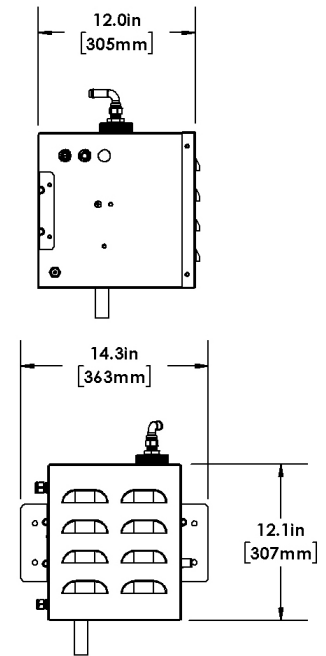

OPTIONS
• Fuel Tank

SERVICE PARTS

Part No.
N/A



HEATER — UNDER DASH

892041-12/24VDC

CONSTRUCTION • ON & OFF-ROAD • FORESTRY

The 4005 is a heavy duty, powder coated black steel casing -high heat output in a compact envelope. Perfect for small to medium size cabs.

**Not Sure What To Order?
We Can Help . . .**

**See the A/C System
Configuration Worksheet
on the last page of this catalog.**

<https://atc.ca>

800-295-4156

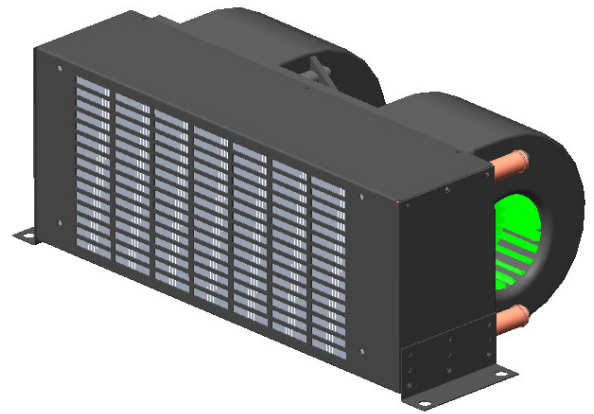

PART NO.

89204112VDC

89204124VDC

SHIPPING NOTICE

This unit can be shipped by UPS.

SPECIFICATIONS

Air Flow.....450 CFM
 Capacity.....44,135 BTU/hr
 Current Draw 14 amps @ 12VDC7 amps @ 24VDC
 Weight 16 LBS
 CoilCopper tube/ Alum. Fin
 Dimensions..... 17.75" L x 15.75" W x 7" H
 Motor Three Speed Blower (Low / Med / High)

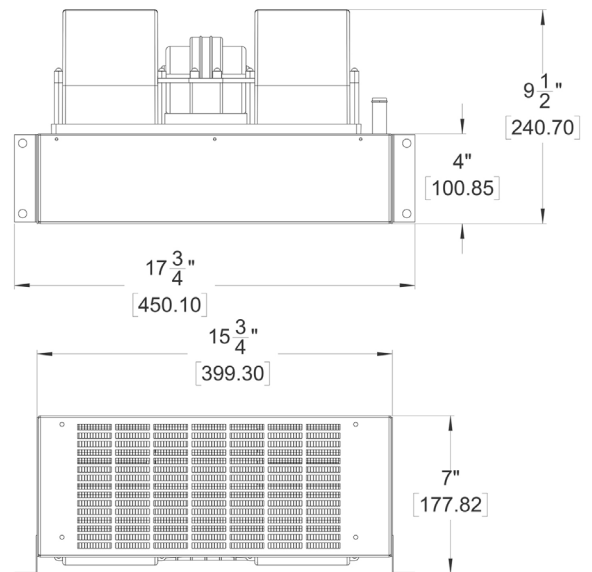

OPTIONS

- 810025 - Digital Controller
- 820086-12/24VDC - Relay Box / Wiring Harness

- Heater Hose Kit

SERVICE PARTS

Part No.

- 876050..... Heating Coil
- 810067..... Blower 12VDC - 3 Spd
- 810068 Blower 24VDC - 3 Spd
- N/A..... External Water Valve Option

HEATER — UNDER DASH

892002-12/24VDC

CONSTRUCTION • ON & OFF-ROAD • FORESTRY

The 4065S is a heavy duty, powder coated black steel casing -high heat output with optional ducting/louver capabilities. Perfect for medium to large size cabs.

**Not Sure What To Order?
We Can Help . . .**

**See the A/C System
Configuration Worksheet
on the last page of this catalog.**

<https://atc.ca>

800-295-4156

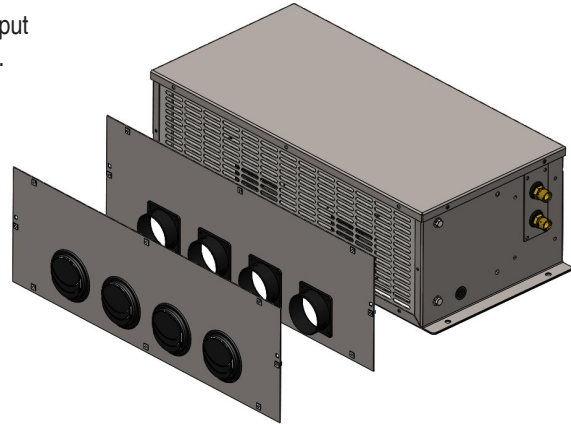

PART NO.

892002 12VDC

892002 24VDC

SHIPPING NOTICE

This unit can be shipped by UPS.

SPECIFICATIONS

Air Flow.....450 CFM
 Capacity.....67,610 BTU/hr
 Current Draw 16 amps @ 12VDC9 amps @ 24VDC
 Weight34 LBS
 CoilCopper tube/ Alum. Fin - Heat Coil
 Dimensions.....26" L x 12.25" W x 8.25" H
 MotorThree Speed (Low / Med / High)

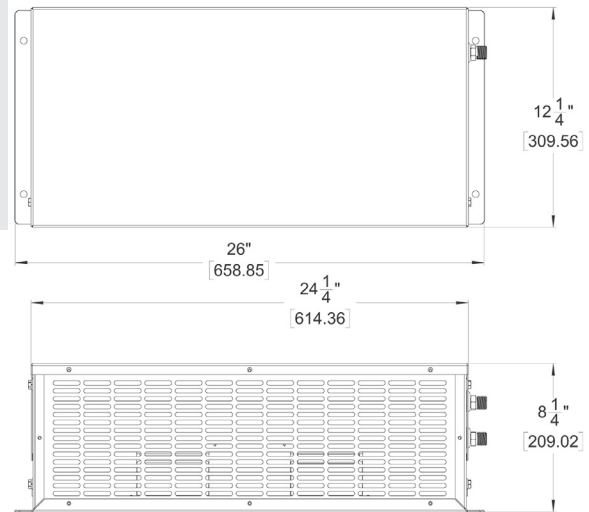

OPTIONS

- 810025 - Digital Controller
- 820086-12/24VD - Relay Box / Wiring Harness
- Optional Pressurizer Kit

SERVICE PARTS

Part No.

876036..... Heating Coil
 810067..... Blower 12VDC - 3 Spd
 810068..... Blower 24VDC - 3 Spd
 N/A..... External Water Valve Option

SELF CONTAINED UNIT — BACK WALL

47-7110

CONSTRUCTION • MINING • FORESTRY • BOOM TRUCK

The 7110 is a heavy duty, wall mounted AC and Heater unit for small cabs. Internal (optional) Hydraulically* Driven Compressor plumbed and wired in. Perfect for boomtrucks or any application where an engine driven compressor is not feasible. External mount.



**Not Sure What To Order?
We Can Help . . .**

**See the A/C System
Configuration Worksheet
on the last page of this catalog.**

<http://www.visionaire-inc.com>
866-838-2810

PART NO.

47-7110-1340 ACH	12VDC
47-7110-2340 ACH	24VDC
47-7110-1341 ACH	12VDC
47-7110-2341 ACH	24VDC
47-7110-1140 ACH	12VDC Engine Drive Compressor
47-7110-2140 ACH	24VDC Engine Drive Compressor

Pressurizer/Fresh Air and Other Configurations Available (call for details)
*Flow Rate and Pressure/PSI Needs Confirmed Prior to Purchase

SHIPPING NOTICE

Due to size and weight this unit must be shipped LTL.

SPECIFICATIONS

Air Flow.....	280 CFM
Capacity.....	Cooling 18,000 BTU/hr.....Heating 16,000 BTU/hr
Current Draw	30 amps @ 12VDC 15 amps @ 24VDC
Weight	125 - 150 LBS
Coil	Copper tube Aluminum Fin
Dimensions.....	20.7" L x 15" W x 26.3" H
Motor	14" Condenser Fan 3 Speed Blower (Low / Med / High)

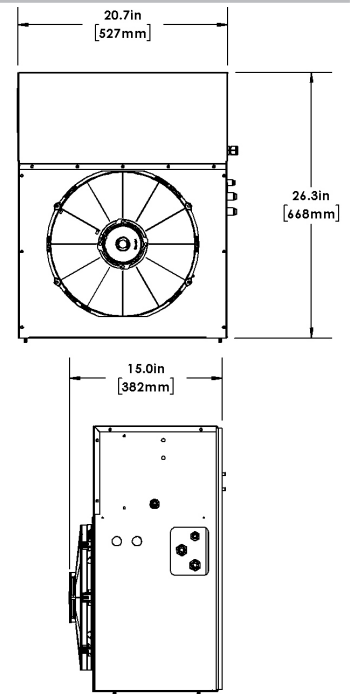

OPTIONS

- 34-7110-001 Control Console
- Pressurizer Kit

- Engine Drive Compressor or Direct Drive (integrated) Compressor
- Refrigeration Hose Kit

SERVICE PARTS

Part No.

10-10-7110	Condenser Coil
10-40-4010	Evap/Heater Coil
14-20-0045	Blower Assembly 12VDC
14-20-0046	Blower Assembly 24VDC
14-10-1410	Cond Fan 12VDC
14-10-1411	Cond Fan 24VDC
12-11-1001	Expansion Valve

Part No.

13-10-1005	Drier
11-10-0032	Compressor
14-80-0210	Hydraulic Motor 12VDC
14-80-0220	Hydraulic Motor 24VDC
12-10-3000	Binary/Pressure Switch
12-31-0001	Water Valve
12-54-1001	Thermostat

SELF CONTAINED UNIT — ROOFTOP — BACK WALL

47-7060

CONSTRUCTION • MINING • FORESTRY • AGRICULTURE • RAIL • UNIVERSAL

The 7060 can be mounted on a vertical or horizontal surface. It's low profile design (only 8" tall) allows this to easily adapt to your machine. An ideal solution for medium size cabs. Internal (optional) Hydraulically* Driven Compressor plumbed and wired in.

**Not Sure What To Order?
We Can Help . . .**

See the A/C System
Configuration Worksheet
on the last page of this catalog.

<http://www.visionaire-inc.com>

866-838-2810



PART NO.

47-7060-1040 ACH	12VDC
47-7060-2040 ACH	24VDC
47-7060-1041 AC Only	12VDC
47-7060-2041 AC Only	24VDC
47-7060-1310H Direct Drive 8GPM ACH	12VDC
47-7060-2310H Direct Drive 8GPM ACH	24VDC

Pressurizer, Fresh Air and Other Alternative Configurations Available (call for details)
*Flow Rate and Pressure/PSI Needs Confirmed Prior to Purchase

SHIPPING NOTICE

Due to size and weight this unit must be shipped LTL.

SPECIFICATIONS

Air Flow.....	420 CFM
Capacity.....	Cooling 30,000 BTU/hrHeating 37,500 BTU/hr
Current Draw	30 amps @ 12VDC 15 amps @ 24VDC
Weight	60 - 165 LBS
Coil	Copper Tubing Alum. Fin Evaporator Micro Channel Condenser
Dimensions.....	38.1" L x 26.7" W x 8" H
Motor	12" Condenser Fan 3 Speed Blower (Low / Med / High)

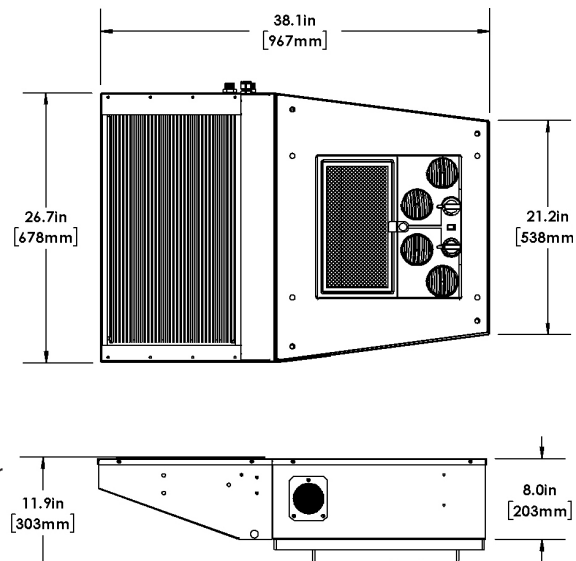

OPTIONS

- 34-7060 Control Console
- Pressurizer Kit
- Engine Drive Compressor or Direct Drive (integrated)
- Compressor or Electric Belt Drive (AC or DC Voltage)
- Refrigeration Hose Kit

SERVICE PARTS

Part No.

10-10-3030.....	Condenser Coil
10-30-4030.....	Heater Coil
12-10-3000.....	Binary/Pressure Switch
12-11-1001.....	Expansion Valve
12-54-1001.....	Thermostat
14-20-0020.....	Blower Assy 12VDC

Part No.

14-20-0021.....	Blower Assy 24VDC
15-10-1017.....	Return Air Filter
14-10-1220.....	Condenser Fan 12VDC
14-10-1221.....	Condenser Fan 24VDC
13-10-1005.....	Drier
12-39-1065.....	Push/Pull Cable (heater)

SELF CONTAINED UNIT — BACK WALL — DUCTABLE

47-7170

CONSTRUCTION • MINING • FORESTRY • AGRICULTURE • RAIL • UNIVERSAL

The 7170 was created with reliability and maintainability as it's key design elements. Delivers 500CFM, runs extremely quiet and features bulkhead mounted hydraulic* fittings that make for a quick, clean install. Plenum allows for multiple ducting options. Ideal for larger cabs. Mounts through wall.



**Not Sure What To Order?
We Can Help . . .**

**See the A/C System
Configuration Worksheet
on the last page of this catalog.**

<http://www.visionaire-inc.com>

866-838-2810

PART NO.

SHIPPING NOTICE

Due to size and weight this unit must be shipped LTL.

47-7170-1340 Direct Drive ACH.....12VDC

47-7170-2340 Direct Drive ACH.....24VDC

Pressurizer, Fresh Air and Other Configurations Available (call for details)

*Flow Rate and Pressure/PSI Needs Confirmed Prior to Purchase

SPECIFICATIONS

Air Flow.....500 CFM
 Capacity.....Cooling 36,000 BTU/hrHeating 47,000 BTU/hr
 Current Draw40 amps @ 12VDC20 amps @ 24VDC
 Weight 150 - 190 LBS
 CoilCopper Tubing Aluminum Fin
 Dimensions.....32.6" L x 29" W x 10.3" H
 Motor 16" Condenser Fan 3 Speed Blower (Low / Med / High)

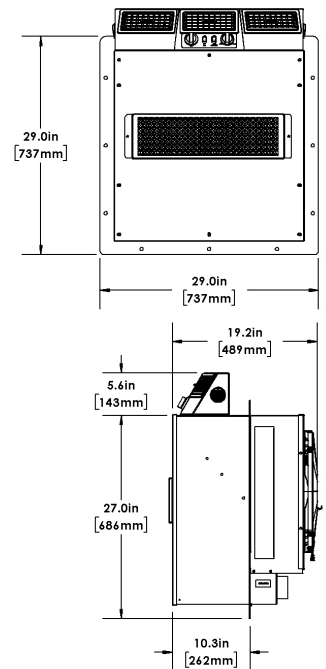

OPTIONS

- 34-7170-100 Control Console
- Pressurizer Kit
- Engine Drive Compressor or Direct Drive (integrated) Compressor
- Remote Located Switches

SERVICE PARTS

Part No.

10-10-7070.....Condenser Coil
 10-40-7170.....Evap/Heater Coil
 14-20-0020.....Blower Fan 12VDC
 14-20-0021.....Blower Fan 24VDC
 12-11-1001.....Expansion Valve
 12-54-1001.....Thermostat

Part No.

14-10-1610.....Condenser Fan 12VDC
 14-10-1611.....Condenser Fan 24VDC
 13-10-3000.....Drier
 12-10-3000.....Binary/Pressure Switch
 11-10-0070.....Compressor

SELF CONTAINED UNIT — ROOFTOP

47-7070

CONSTRUCTION • MINING • RAIL • UNIVERSAL

The 7070 is a heavy duty, roof mounted A/C and heat system for large cabs. Three speed blower offering 500 CFM. Proven design that is able to deliver the performance needed in high ambient, tough environments. Can be plate mounted to accommodate pressurizer.

**Not Sure What To Order?
We Can Help . . .**

See the A/C System
Configuration Worksheet
on the last page of this catalog.

<http://www.visionaire-inc.com>

866-838-2810



PART NO.

47-7070-1040 ACH..... 12VDC

47-7070-2040 ACH..... 24VDC

47-7070-1041 AC Only..... 12VDC

47-7070-2041 AC Only..... 24VDC

SHIPPING NOTICE

Due to size and weight this unit must be shipped LTL.

Pressurizer, Fresh Air and Other Alternative Configurations Available (call for details)

*Flow Rate and Pressure/PSI Needs Confirmed Prior to Purchase

SPECIFICATIONS

Air Flow..... 500 CFM

Capacity..... Cooling 36,000 BTU/hr Heating 47,000 BTU/hr

Current Draw 28 amps @ 12VDC 14 amps @ 24VDC

Weight 150 - 222 LBS

Coil Copper Tubing Alum. Fin Evaporator Micro Channel Condenser

Dimensions..... 40.4" L x 28.7" W x 11" H

Motor 14" Condenser Fan 3 Speed Blower (Low / Med / High)

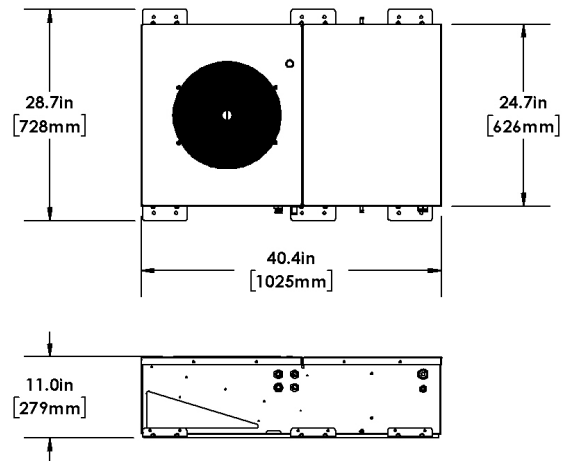

OPTIONS

- 34-7070 200 Control Console
- Pressurizer Kit
- Engine Drive Compressor or Direct Drive (integrated) Compressor

- Plate Mount Kit (7070 P)
- Hose Kit

SERVICE PARTS

Part No.

10-10-7070 Condenser Coil
 10-40-7170 Evap/Heater Coil
 14-20-0020 Blower Fan 12VDC
 14-20-0021 Blower Fan 24VDC
 12-11-1202 Expansion Valve
 12-54-1001 Thermostat
 14-10-1420 Condenser Fan 12VDC

Part No.

14-10-1421 Condenser Fan 24VDC
 13-10-3000 Drier
 12-54-1001 Thermostat
 15-10-1010 Return Air Filter
 12-10-1001 High Pressure Switch
 12-10-2001 Low Pressure Switch

SELF CONTAINED UNIT — ROOFTOP

47-7070 BD

CONSTRUCTION • MINING • RAIL • UNIVERSAL

The 7070 BD is a heavy duty, roof mounted A/C and heat system for large cabs. Three speed blower offering 500CFM. The 7070 BD offers either a Hydraulically* Driven Compressor plumbed and wired In or an Electrically Driven Compressor, plate mounted. Proven design that is able to deliver the performance needed in high ambient, tough environments. Optional pressurizer kit available (7070 BDP).

**Not Sure What To Order?
We Can Help . . .**

**See the A/C System
Configuration Worksheet
on the last page of this catalog.**

<http://www.visionaire-inc.com>

866-838-2810



PART NO.

47-7070-1200 ACH..... 12VDC
47-7070-2200 ACH..... 24VDC
47-7070-1201 AC Only..... 12VDC
47-7070-2201 AC Only..... 24VDC

SHIPPING NOTICE

Due to size and weight this unit must be shipped LTL.

*Flow Rate and Pressure/PSI Needs Confirmed Prior to Purchase

SPECIFICATIONS

Air Flow.....500 CFM
 Capacity.....Cooling 36,000 BTU/hrHeating 47,000 BTU/hr
 Current Draw28 amps @ 12VDC14 amps @ 24VDC
 Weight300 - 335 LBS
 CoilCopper Tubing Alum. Fin Evaporator Micro Channel Condenser
 Dimensions.....54" L x 32" W x 10.9" H
 Motor14" Condenser Fan 3 Speed Blower (Low / Med / High)

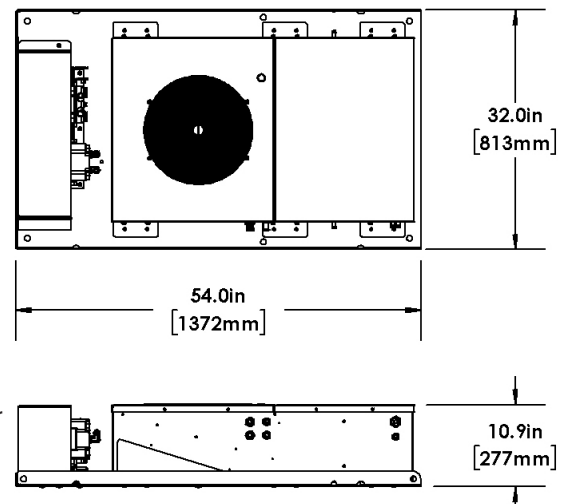

OPTIONS

- 34-7070-200 Control Console
- Pressurizer Kit (BDP)

- Hydraulic or Electric Drive Motor

SERVICE PARTS

Part No.

10-10-7070.....Condenser Coil
 10-40-7170.....Evap/Heater Coil
 14-20-0020.....Blower Fan 12VDC
 14-20-0021.....Blower Fan 24VDC
 12-11-1202.....Expansion Valve
 12-54-1001.....Thermostat
 14-10-1420.....Condenser Fan 12VDC

Part No.

14-10-1421.....Condenser Fan 24VDC
 13-10-3000.....Drier
 15-10-1010.....Return Air Filter
 11-10-4513.....Compressor 12VDC
 11-10-4521.....Compressor 24VDC
 12-10-1001.....High Pressure Switch
 12-10-2001.....Low Pressure Switch

SELF CONTAINED UNIT — BACK WALL — DUCTABLE

47-7100

CONSTRUCTION • MINING • FORESTRY • AGRICULTURE • RAIL • UNIVERSAL

The 7100 compact air conditioner is designed as an outside wall mount unit. A small operator cab with limited available space makes this unit ideal. Available Options include an Internal Hydraulically* Driven Compressor plumbed and wired in.

**Not Sure What To Order?
We Can Help . . .**

**See the A/C System
Configuration Worksheet
on the last page of this catalog.**

<http://www.visionaire-inc.com>

866-838-2810



<u>PART NO.</u>	<u>SHIPPING NOTICE</u>
47-7100-1001 AC Only 12VDC	Due to size and weight this unit must be shipped LTL.
47-7100-2001 AC Only 24VDC	
47-7100-1301 Direct Drive AC Only 12VDC	
47-7100-2301 Direct Drive AC Only 24VDC	

*Flow Rate and Pressure/PSI Needs Confirmed Prior to Purchase

SPECIFICATIONS

Air Flow.....250 CFM
 Capacity.....Cooling 16,000 BTU/hr
 Current Draw 15 amps @ 12VDC7 amps @ 24VDC
 Weight60 - 150 LBS
 CoilCopper Tubing Aluminum Fin
 Dimensions.....30.6" L x 20.8" W x 12.6" H
 Motor9" Condenser Fan 3 Speed Blower (Low / Med / High)

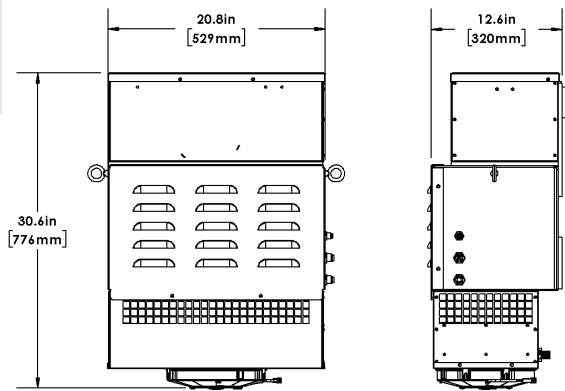

- OPTIONS**
- 7100 Control Console
 - Pressurizer Kit

- Refrigeration Hose Kit

SERVICE PARTS

<u>Part No.</u>	
10-10-3000.....	Condenser Coil
10-20-4000.....	Evaporator Coil
14-20-3013.....	Blower Fan 12VDC
14-20-3014.....	Blower Fan 24VDC
12-11-1001.....	Expansion Valve

<u>Part No.</u>	
12-54-1001.....	Thermostat
14-10-0911.....	Condenser Fan 12VDC
14-10-0921.....	Condenser Fan 24VDC
13-10-1000.....	Drier
11-10-0031.....	Compressor

SELF CONTAINED UNIT — ROOFTOP

47-7000

CONSTRUCTION • UNIVERSAL

The Model 7000 is ideal for skid steers, mini excavators, forklifts, loaders. The compact design allows for mounting to small operator cabs with limited roof space. The all steel construction makes this unit last in those harsh environments.

**Not Sure What To Order?
We Can Help . . .**

**See the A/C System
Configuration Worksheet
on the last page of this catalog.**

<http://www.visionaire-inc.com>

866-838-2810



PART NO.

47-7000-1001 AC Only12VDC

47-7000-2001 AC Only24VDC

SHIPPING NOTICE

Due to size and weight this unit must be shipped LTL.

SPECIFICATIONS

Air Flow.....250 CFM
 Capacity.....Cooling 16,000 BTU/hr
 Current Draw15 amps @ 12VDC7 amps @ 24VDC
 Weight60 LBS
 CoilCopper Tubing Aluminum Fin
 Dimensions.....20.5" L x 20.9" W x 9.5" H
 Motor9" Condenser Fan 3 Speed Blower (Low / Med / High)

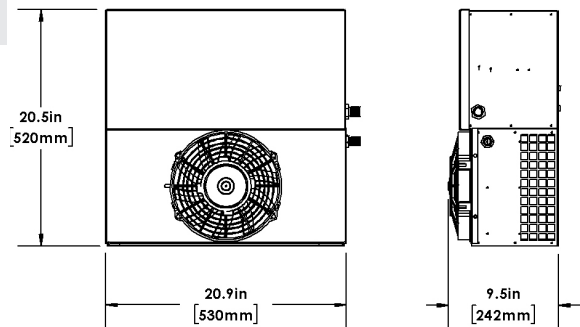

OPTIONS

- 32-7000 Control Console
- Engine Drive Compressor or Direct Drive (integrated) Compressor
- Pressurizer Kit
- Refrigeration Hose Kit

SERVICE PARTS

Part No.

10-10-3000.....Condenser Coil
 10-20-4000.....Evaporator Coil
 14-20-3013.....Blower Fan 12VDC
 14-20-3014.....Blower Fan 24VDC
 12-11-1001.....Expansion Valve

Part No.

12-54-1001.....Thermostat
 14-10-0911.....Condenser Fan 12VDC
 14-10-0921.....Condenser Fan 24VDC
 13-10-1000.....Drier

SELF CONTAINED UNIT — DUCTABLE

47-7115

CONSTRUCTION • AGRICULTURE • FORESTRY • UNIVERSAL

The 7115 is a versatile, self-contained Hydraulic* Drive Air Conditioning/Heating unit built to withstand mechanical abuse and harsh conditions. The system is easily configured to meet multiple mounting and cooling/heating requirements as the condenser fan can be on the left or right. The 7115 can be installed on a exterior cabin wall or deck mounted and ducted into the cabin. Coolant or diesel heat options are available.

Not Sure What To Order? We Can Help . . .

See the A/C System
Configuration Worksheet
on the last page of this catalog.

<http://www.visionaire-inc.com>

866-838-2810



PART NO.

47-7115-1340 AC Only 12VDC
47-7115-2340 AC Only 24VDC

SHIPPING NOTICE

Due to size and weight this unit must be shipped LTL.

*Call for AC+Heater Configurations

*Flow Rate and Pressure/PSI Needs Confirmed Prior to Purchase

SPECIFICATIONS

Air Flow.....200 CFM
Capacity.....Cooling 18,000 BTU/hr.....Optional Air Heating
Current Draw30 amps @ 12VDC15 amps @ 24VDC
Weight185 LBS
Condenser CoilCopper Tubing Aluminum Fin
Dimensions.....24.8" L x 26.5" W x 20.8" H
Motor14" Condenser Fan 3 Speed Blower (Low / Med / High)

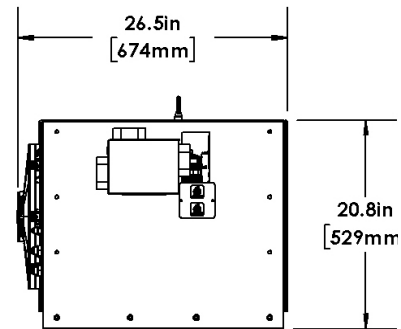
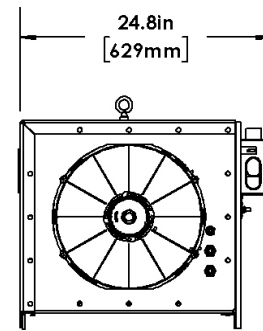

OPTIONS

- Diesel Heater
- Pressurizer Kit

- Left or Right Side Condenser Fan

SERVICE PARTS

Part No.

10-10-7110 Condenser Coil
10-20-7110 Evaporator/Heat Coil
14-20-0045 Blower Assembly 12VDC
14-20-0046 Blower Assembly 24VDC
12-11-1001 Expansion Valve

Part No.

12-54-1001 Thermostat
14-10-1410 Condenser Fan 12VDC
14-10-1411 Condenser Fan 24VDC
13-10-2003 Drier
12-39-1065 Push/Pull Cable (heater)

SELF CONTAINED UNIT — BACK WALL — DUCTABLE

47-7150

CONSTRUCTION • AGRICULTURE • FORESTRY • UNIVERSAL

The 7150 delivers impressive performance for medium size work equipment cabs. Several variations are available to suit direct blow or ducted outlets, cab pressurization, and various vehicle hydraulic systems. Optional smart system capability can incorporate J1939 or can open language protocol. Mounts through wall.



Not Sure What To Order? We Can Help . . .

See the A/C System
Configuration Worksheet
on the last page of this catalog.

<http://www.visionaire-inc.com>

866-838-2810

PART NO.

47-7150-1340 AC Only..... 12VDC

47-7150-2340 AC Only..... 24VDC

SHIPPING NOTICE

Due to size and weight this unit must be shipped LTL.

*Flow Rate and Pressure/PSI Needs Confirmed Prior to Purchase

SPECIFICATIONS

Air Flow.....420 CFM
Capacity.....Cooling 30,000 BTU/hr.....Heating 37,500 BTU/hr
Current Draw30 amps @ 12VDC20 amps @ 24VDC
Weight215 LBS
CoilCopper Tubing Aluminum Fin
Dimensions.....27" L x 25" W x 18.3" H
Motor14" Condenser Fan 3 Speed Blower (Low / Med / High)

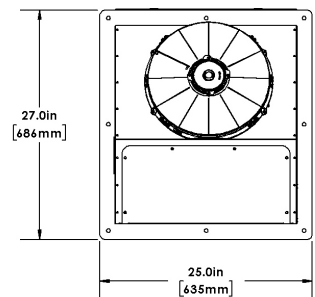
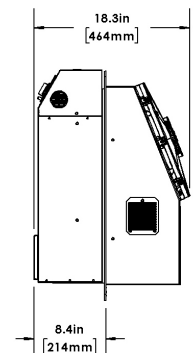

OPTIONS

- Smart System ECU
- Pressurizer Kit
- Engine Drive Compressor or Direct Drive (integrated) Compressor

SERVICE PARTS

Part No.

10-10-0060.....Condenser Coil
10-20-4030.....Evaporator Coil
10-30-4030.....Heater Coil
14-20-0020.....Blower Fan 12VDC
14-20-0021.....Blower Fan 24VDC
14-10-1410.....Condenser Fan 12VDC

Part No.

14-10-1411.....Condenser Fan 24VDC
12-11-1001.....Expansion Valve
13-10-1005.....Drier
12-10-3000.....Binary/Pressure Switch
12-54-1001.....Thermostat
11-10-0071.....Compressor

SELF CONTAINED UNIT — ROOFTOP

47-7055

CONSTRUCTION • AGRICULTURE • FORESTRY • UNIVERSAL

The 7055 is a roof mounted, engine drive air conditioner that is sure to impress! With an impressive 27,000 BTU of cooling and optional heat configuration, this unit is a great fit on top of a small cab or trailer.

**Not Sure What To Order?
We Can Help . . .**

**See the A/C System
Configuration Worksheet
on the last page of this catalog.**

<http://www.visionaire-inc.com>
866-838-2810



PART NO.

47-7065-1000 ACH..... 12VDC
47-7065-2000 ACH..... 24VDC

SHIPPING NOTICE

This unit can be shipped by UPS.

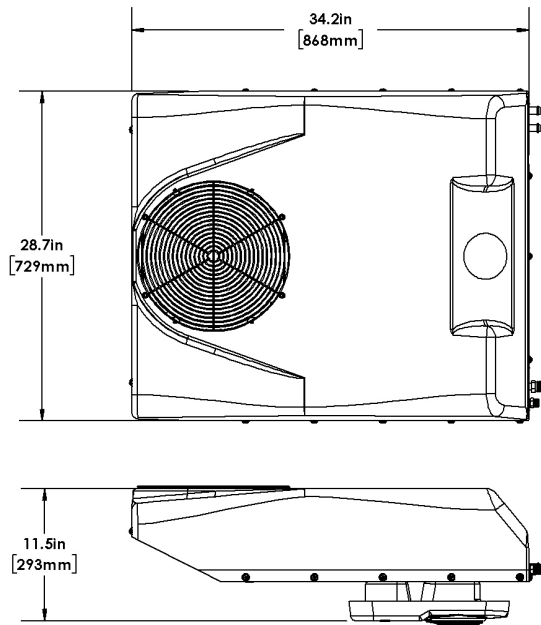

SPECIFICATIONS

Air Flow.....400 CFM
Capacity.....Cooling 27,000 BTU/hr.....Heating 36,000 BTU/hr
Current Draw25.9 amps @ 12VDC 14.2 amps @ 24VDC
Weight50 LBS
CoilCopper Tubing Aluminum Fin Micro Channel Coil
Dimensions.....34.2" L x 28.7" W x 11.5" H
Motor12" Condenser Fan 3 Speed Blower (Low / Med / High)

OPTIONS

- AC Only
- AC + Heat
- Compressor
- Hose Kit
- Compressor Mount

SERVICE PARTS

Part No.

10-10-3025.....Condenser Coil
14-10-1234.....Cond Fan 12VDC
13-10-1005.....Drier
12-11-1001.....Expansion Valve
10-40-7065.....Evap Coil



A/C & HEATER UNITS

SELF CONTAINED UNIT — ROOFTOP

890050-12/24VDC - AC Only
890066-12/24VDC - AC & Heat

CONSTRUCTION • ON & OFF-ROAD

The 5600 is a heavy duty, powder coated white steel self-contained rooftop HVAC unit. Perfect for small to medium size cabs.

**Not Sure What To Order?
We Can Help . . .**

**See the A/C System
Configuration Worksheet
on the last page of this catalog.**

<https://atc.ca>

800-295-4156

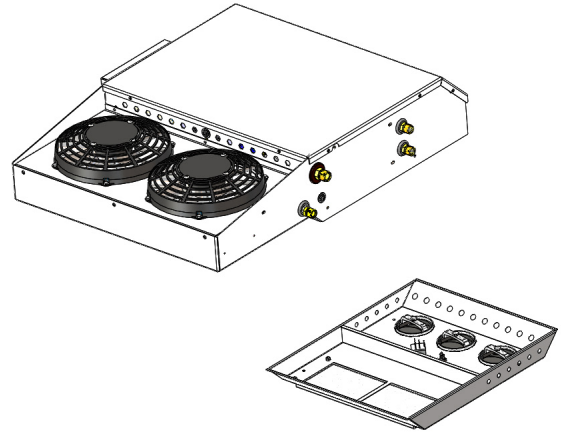

PART NO.

890050	12VDC AC Only
890050	12VDC AC Only
890066	12VDC AC & Heat
890066	12VDC AC & Heat

SHIPPING NOTICE

This unit can be shipped by UPS or LTL.

Fresh Air Option Available

SPECIFICATIONS

Air Flow.....	400 CFM
Capacity.....	Cooling 22,000 BTU/hr.....Heating 25,000 BTU/hr
Current Draw	30 amps @ 12VDC16.5 amps @ 24VDC
Weight	52 LBS
Coil	Copper Tubing / Alum. Fin - Fin Condenser, Evap & Heat Coils
Dimensions.....	30.5" L x 22" W x 6.5" H
Motor	2 x 9" Condenser Fan 3 Speed Blower (Low / Med / High)

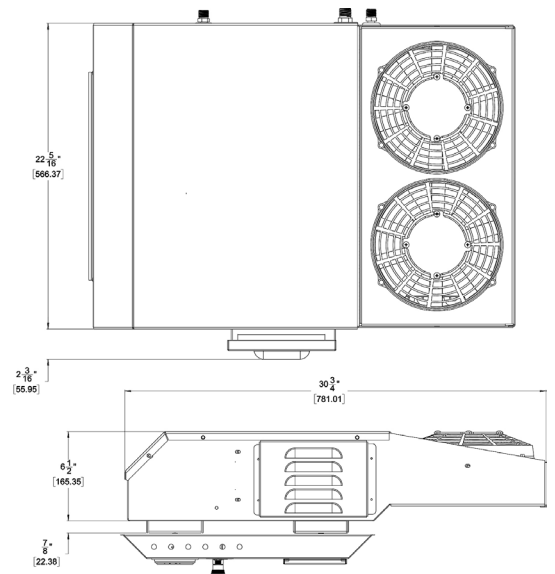

OPTIONS

- 810025 - Digital Controller
- 8820086-12/24VD - Relay Box / Wiring Harness
OR 1151 3-Speed fan switch
- 810072A - Red Light Switch
- 1030 - Toggle switch
- Optional Pressurizer Kit
- Engine Driven Compressor
- Refrigeration Hose Kit

SERVICE PARTS

Part No.

875026.....	Condenser Coil
870089.....	Evap Coil
876027.....	Heat Coil
810062.....	Blower Assembly 12VDC
810064.....	Blower Assembly 24VDC
3500.....	Cond Fan 12VDC

Part No.

3499.....	Cond Fan 24VDC
1600.....	Expansion Valve
7502.....	Drier
1512.....	Pressure Switch
N/A.....	External Water Valve Option

CONSTRUCTION • ON & OFF-ROAD • FORESTRY

The ATC 60/100 HP is a heavy duty, powder coated white steel pressurizer perfect for medium size cabs operating in mining/highly polluted environments.

**Not Sure What To Order?
We Can Help . . .**

See the **A/C System
Configuration Worksheet**
on the last page of this catalog.

<https://atc.ca>

800-295-4156

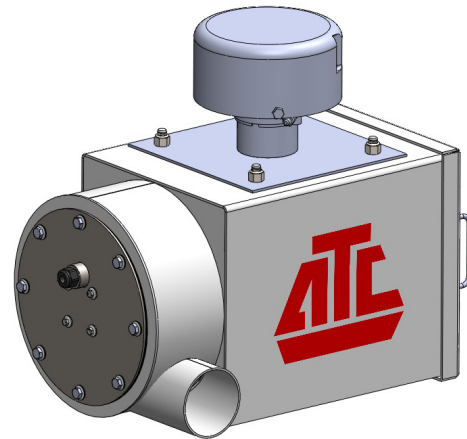

PART NO.

- 896052ATC** 12VDC
- 896052AT** 12/24VDC
- 896052ATC** HP-24VDC

SHIPPING NOTICE

This unit can be shipped by UPS or LTL.

SPECIFICATIONS

- Air Flow.....50 CFM, 100 CFM (HP)
- Capacity.....Filter Min Efficiency: 99.97% of 0.3 µm. Particles @ 170 CFM
- Current Draw2.35 amps @ 12VDC. 1.17 amps @ 24VDC
3.22 amps @ 24VDC (HP)
- Weight30 LBS
- Dimensions.....16" L x 9.875" W x 15.25" H
- MotorFixed Speed, Variable Speed w/ Controller

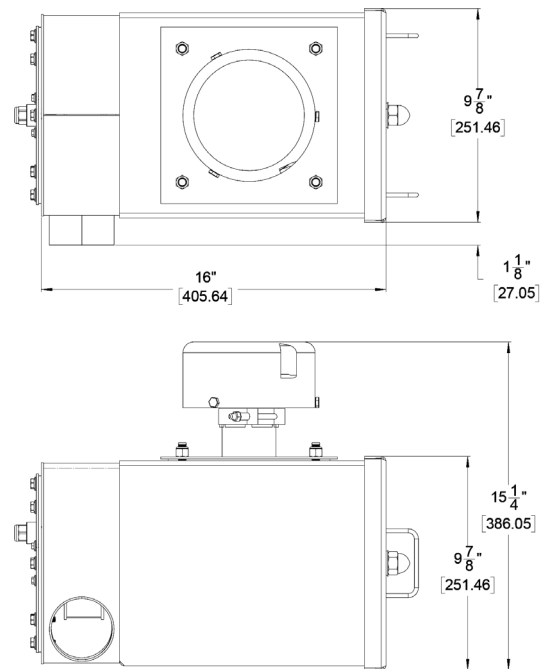

OPTIONS

- 810025 - Digital Controller
- 820086-12/24VD - Relay Box / Wiring Harness
- Pressurizer Kit

SERVICE PARTS

- Part No.**
- 810143..... Impeller fan 24VDC
- 810152..... Impeller fan 24VDC - HP
- 810149..... Impeller fan -12VDC



HEPA CAB PRESSURIZER — EXTERNAL/INTERNAL

896068ATC

CONSTRUCTION • ON & OFF-ROAD • FORESTRY

The ATC 200 is a Heavy Duty, Powder Coated White Steel pressurizer perfect for medium size cabs operating in mining/highly polluted environments.

Not Sure What To Order? We Can Help . . .

See the A/C System Configuration Worksheet on the last page of this catalog.

https://atc.ca

800-295-4156

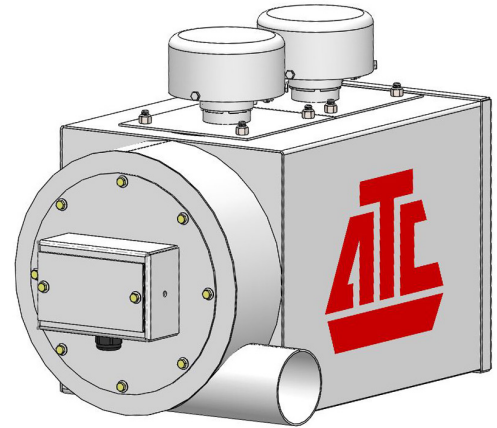

PART NO.

896068ATC115VDC

896068AT230VDC

SHIPPING NOTICE

This unit can be shipped by UPS or LTL.

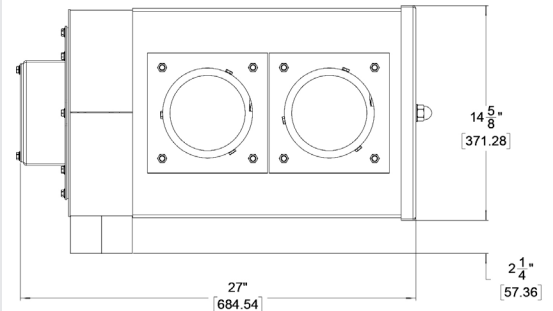

SPECIFICATIONS

- Air Flow..... 150 CFM
- Capacity..... Filter Min Efficiency: 99.97% of 0.3 µm. Particles @ 170 CFM
- Current Draw 1.5 amps @ 115VDC0.85 amps @ 230VDC
3.22 amps @ 24VDC (HP)
- Weight54 LBS + 24 LBS Filter
- Dimensions.....27" L x 14.6250" W x 19.5" H
- Motor Fixed Speed

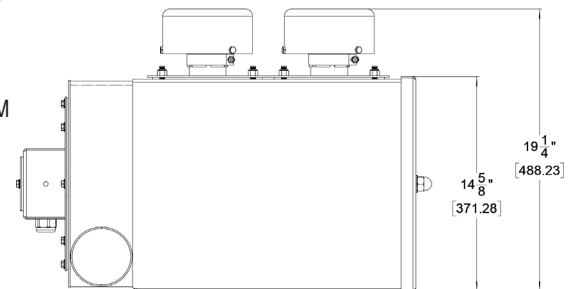

- OPTIONS**
- 810025 - Digital Controller
 - 820086-12/24VD - Relay box / Wiring Harness
 - Pressurizer Kit

SERVICE PARTS

- Part No.**
- 810150..... Impeller fan 115 VAC
 - 810154..... Impeller fan 230 VAC.

HYDRAULIC DIRECT DRIVE COMPRESSORS

41-1200: Hydraulically Driven AC Compressor. Belt Drive Unit. Must Verify flow in both GPM and PSI. Multiple Configurations Available.

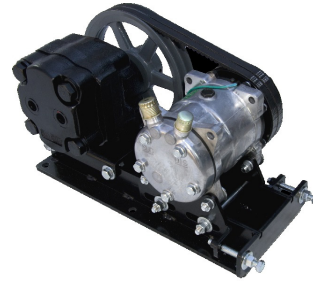

41-1300: Hydraulically Driven AC Compressor. Direct Drive Unit, External Valve. Must Verify flow in both GPM and PSI. Multiple Configurations Available.

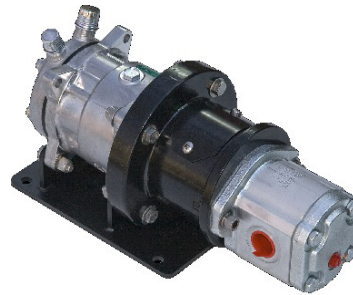

41-1310: Hydraulically Driven AC Compressor. Direct Drive Unit, Built in Valve. Must Verify flow in both GPM and PSI. Multiple Configurations Available.

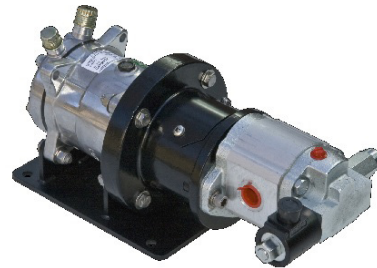

41-1320: Hydraulically Driven AC Compressor. Direct Drive Unit, Internal or External Valve. Must Verify flow in both GPM and PSI. Multiple Configurations Available.

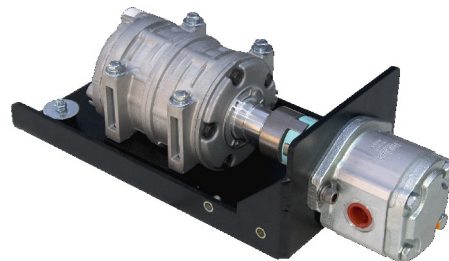

Please call Visionaire at 866-838-2810 to discuss application needs for Direct Drive Units as there are multiple options and configurations to choose from

SUPPLEMENTAL INFORMATION



<https://atc.ca>
800-295-4156

1416 Graham's Lane
Burlington, Ontario
Canada, L7S 1W3



www.hammondac.com
800-267-2665

125 Samnah Crescent
Ingersoll, Ontario, N5C 3J7



VISIONAIRE, INC.

www.visionaire-inc.com
866-838-2810

1401 Valley View Lane #135
Irving, TX 75061

NO IDLE ARCTIC BREEZE TRUCK A/C SYSTEM

12VDC/24VDC

TRUCK • HEAVY EQUIPMENT

The 12VDC/24VDC Arctic Breeze Truck A/C System lets you stay cool while not idling your engine, saving you money on fuel, maintenance, and machine hours. Utilizes standard automotive A/C components for ease of serviceability.

The condenser/compressor box is made from 1/8" aluminum and can be mounted directly behind the cab or hung off the frame rails with the brackets provided. The standard set-up requires 27 1/4" of

frame rail space and extends 19 1/2" from the frame. An optional space saving design utilizes 16" of frame rail space and extends 26 1/2" out from the frame. It features a removable lid for easy access to all the components. The condenser utilizes 2 power fans to better dissipate the heat, and the evaporator assembly incorporates a highly efficient blower to provide more air circulation in the cab/sleeper. The evaporator can be mounted on a shelf, directly on the back wall of the cab, or in a storage compartment (sleeper applications).



12VDC TRUCK UNIT A/C HOSE PLUMBING

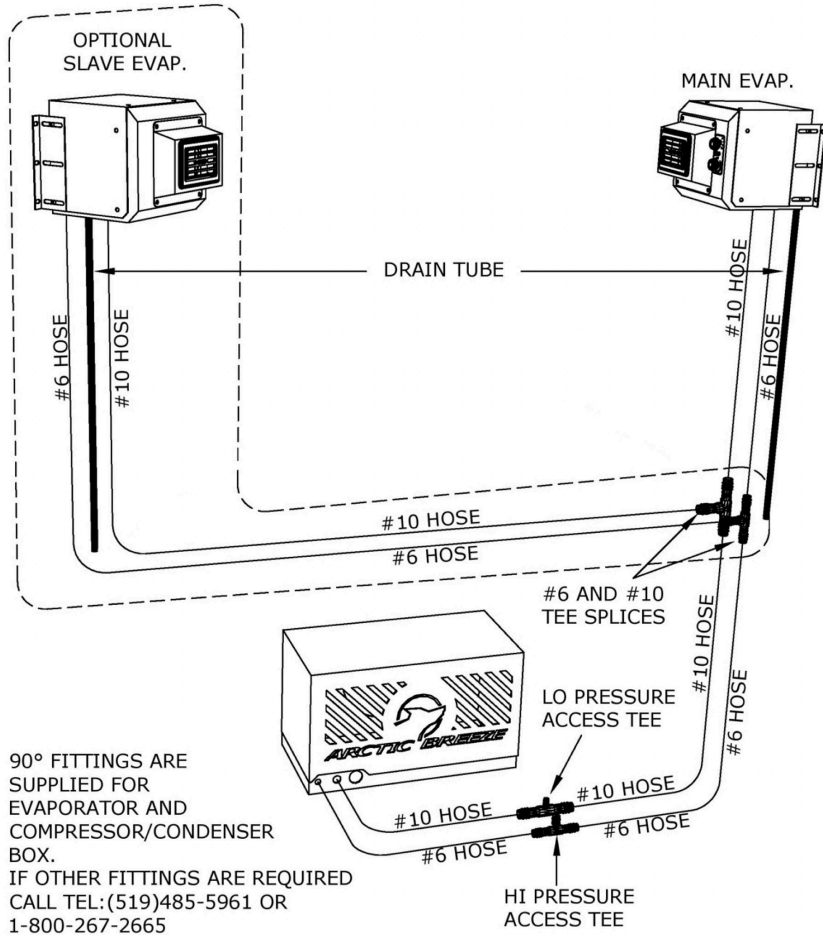

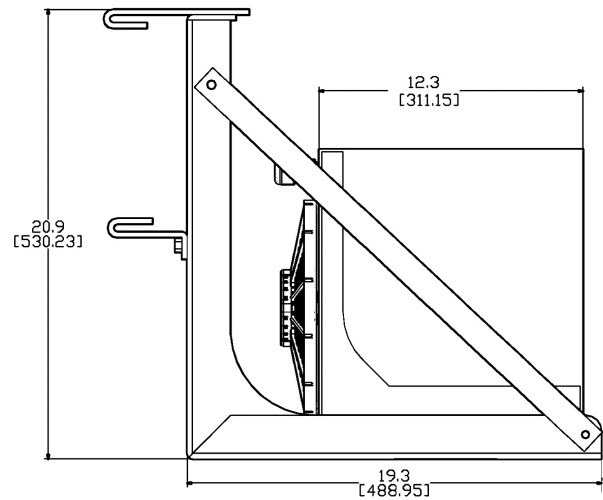
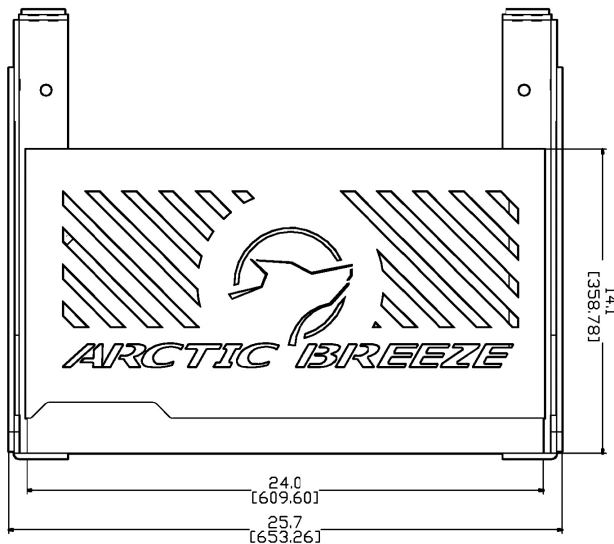
NO IDLE ARCTIC BREEZE TRUCK A/C SYSTEM
12V/24VDC
TRUCK • HEAVY EQUIPMENT

PART NO.

HA-12VDC-SD	Single Evaporator
HA-12VDC-SDDC	Single Day Cab Evaporator
HA-12VDC-DD	Dual Evaporator (Studio Sleeper)

SPECIFICATIONS

Airflow	306 CFM
Capacity	8,000 BTU/Hr Cooling
	10,000 BTU/Hr with Dual Evap
Current Draw (max)	45 amps @ 12VDC
Current Draw (average)	29 amps @ 12VDC

Minimum Alternator	180 amp
Frame Space Required	27.24"
Frame Space Required (alternate)	16"
Total System Weight	200 lbs
Refrigerant	R-134a

OPTIONS

- HA-1200-2A..... Battery Box with Hardware (holds 2 group 31 batteries)
- 520-1206-HDW..... Narrow Frame Rail Kit
- 520-12VDC-2102A... Slave Evaporator with hoses
- 24VDC options available upon request
- Heat Options Available

SERVICE PARTS
Part No.

HA-12VDC-EVMS	12V Evaporator Assembly with Miscellaneous Parts
520-5072A	Compressor, 12VDC
415-1000	Motor 0.5HP, 12VDC, 50amp
520-12VDC-210SP	12VDC Evaporator Assembly
	See separate parts breakdown
420-908A	Condenser Coil

Part No.

430-040-DFW	10" Condenser Fans, 12VDC
K TRUCK COND-2	12VDC Dual Fan Condenser/Compressor Assembly
HA-1201	Frame Rails
523-037-9	Receiver Drier
412-154	Binary Switch
4L-200W	Belt

NO IDLE ARCTIC BREEZE SPLIT A/C SYSTEM

12VDC/24VDC

TRUCK • HEAVY EQUIPMENT

The 12VDC/24VDC Arctic Breeze Truck A/C Split System lets you stay cool while not idling your engine, saving you money on fuel, maintenance, and machine hours. Utilizes standard automotive A/C components for ease of serviceability.

This variation of our original 12VDC/24VDC No Idle Arctic Breeze A/C System is perfect for trucks and heavy equipment that don't have the space to mount the condenser/compressor box. This

system utilizes a compressor/motor box that can be mounted inside the bunk of your cab, beneath the bed or anywhere there is space on your heavy equipment. A remote power condenser can be mounted on the back of a cab. Mounting locations are flexible for your specific needs. It features a removable lid for easy access to all the components. The condenser utilizes a power fan to better dissipate the heat, and the evaporator assembly incorporates a highly efficient blower to provide more air circulation in the cab/sleeper.



12VDC SPLIT A/C HOSE PLUMBING DIAGRAM

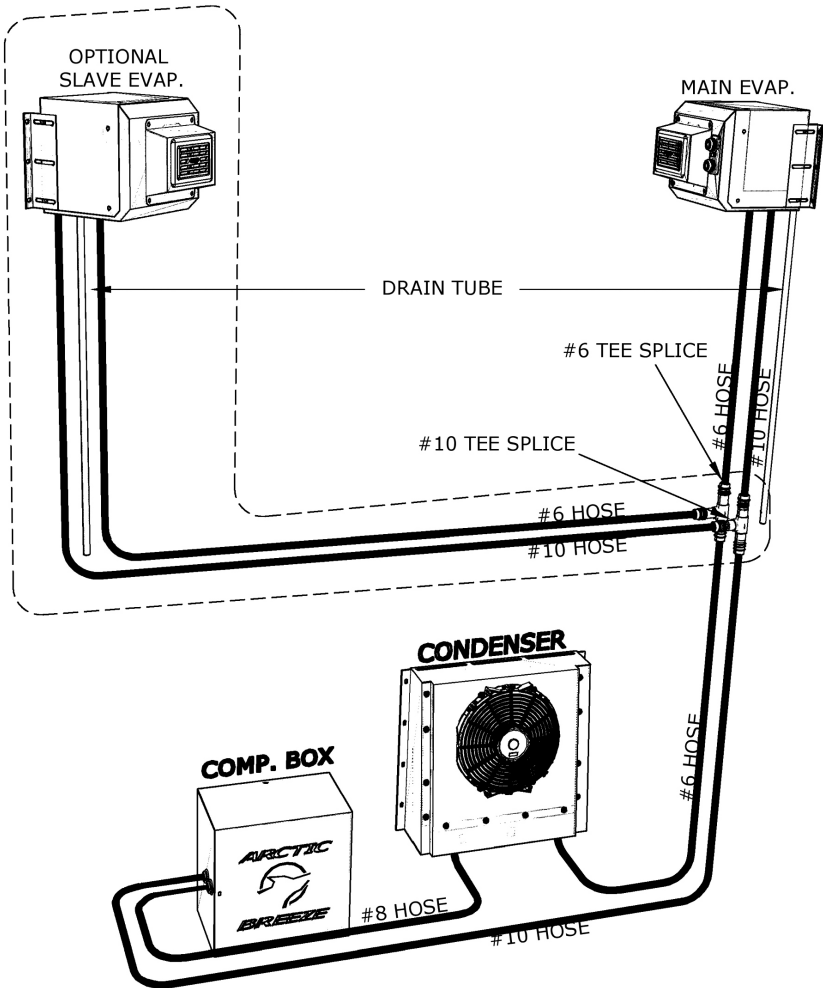

NO IDLE ARCTIC BREEZE SPLIT A/C SYSTEM

12V/24VDC

TRUCK • HEAVY EQUIPMENT

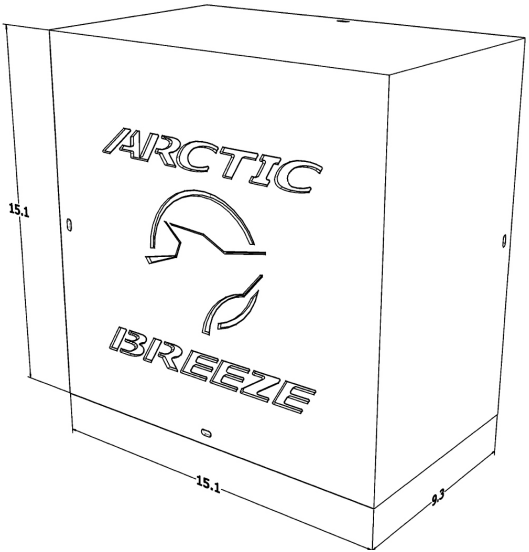
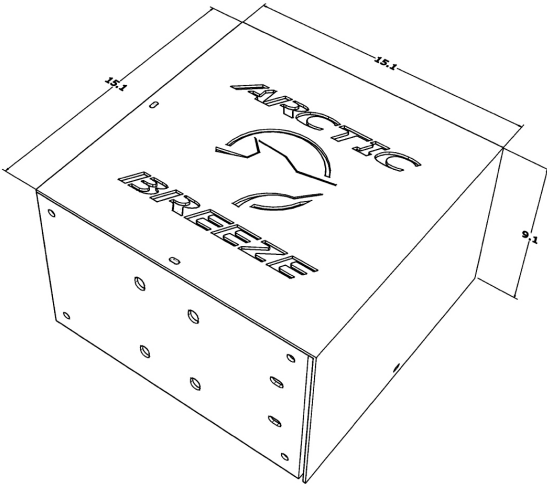

PART NO.

HA-12VDC-SPLITSingle Evaporator, Horizontal Compressor Box

HA-12VDC-SPLIT-VSingle Evaporator, Vertical Compressor Box

HA-12VDC-SPLITDCSingle Day Cab Evaporator, Horizontal Compressor Box

SPECIFICATIONS

Airflow 306 CFM
 Capacity..... 8,000 BTU/Hr Cooling
 10,000 BTU/Hr with Dual Evap
 Current Draw (max) 45 amps @ 12VDC
 Current Draw (average)..... 29 amps @ 12VDC

Minimum Alternator 180 amp
 Total System Weight 200 lbs
 Refrigerant..... R-134a

OPTIONS

- HA-1200-2A.....Battery Box with Hardware (holds 2 group 31 batteries)
- 520-12VDC-2102A....Slave Evaporator with hoses

- 24V Options available Upon Request
- Heat Options Available

SERVICE PARTS

Part No.

HA-12VDC-210SP 12VDC Evaporator Assembly
 See separate parts breakdown
 K TRUCK COND SPLIT 12VDC Split Cond Assy
 See separate parts breakdown
 520-5077SD-A..... Compressor, 12VDC

Part No.

415-1002 Motor 0.5HP, 12VDC, 50amp
 AM-23 Belt
 412-154 Binary Switch
 430-104 Compressor Cooling Fan

A/C & HEATER UNITS



ARCTIC BREEZE ROOFTOP A/C

HA-12VDC-1200
HA-24VDC-1800

MARINE • RV • TRUCK • HEAVY EQUIPMENT

The rugged Arctic Breeze system is virtually maintenance free and comes pre-charged with R134a refrigerant. The aluminum construction and tough polyethylene shell is made to resist corrosion, while Weather Pack electrical connections and sealed motor provide for a long service life.

The integrated low voltage cut out switch and low power consumption means hours of cooling without fear of draining the batteries. This is not just another RV rooftop unit, but one designed to meet heavy truck, marine and heavy off-road equipment needs.



PART NO.

HA-12VDC-1200 12VDC – 12,000 BTU Cooling
HA-24VDC-1800 24VDC – 18,000 BTU Cooling

SPECIFICATIONS

Airflow 649 CFM
Capacity 12,000 or 18,000 BTU
Current Draw 43 amps @ 12V, 39 amps @ 24VDC

OPTIONS • HA-1200-2A.....Battery Box with Hardware

SERVICE PARTS

Part No.

401-900.....Replacement cover
200-003.....Drier Assembly
411-300-100.....Evaporator Assembly
412-154.....Binary Switch
420-912.....Condenser Coil
514-410.....Expansion Valve
520-5077SD-A.....Compressor, 12VDC
4L-210.....Belt, 12VDC
520-5123-A.....Compressor, 24VDC
215K5.....Belt, 24VDC
415-1000.....Electric Motor, 12VDC

Part No.

111-051.....Rotary Thermostat
415-1023.....Electric Motor, 24VDC
412-102.....4 Position Switch
401-831.....Blower, 12VDC
411-058.....Fan Control Knob
401-830.....Blower, 24VDC
411-064.....Snowflake Knob
430-040-DFW.....10" Power Fan, 12VDC
411-846.....Louver
430-040-24.....10" Power Fan, 24VDC
435-012.....Filter

ARCTIC WOLF™ AFTERMARKET AIR CONDITIONING KITS



As a designer and system developer, Hammond Air Conditioning Ltd. has a reputation of being able to air condition “anything with a cab and an engine”. Supplying dealers with air conditioning kits and installations for such brand names as Caterpillar, Case, John Deere, Komatsu and Liebherr, just to name a few, we have become recognized as one of the premiere mobile equipment air conditioning companies in Canada.

The kits are designed with completely integrated evaporators and controls, when available. Most systems utilize a condenser mounted in the engine fan airflow. Our own heavy duty condenser is designed for the most severe conditions, such as forestry and landfill applications, with a 1/4” plate construction case and 3/16” sides. Most systems are designed for the integrated ‘factory’ styled

appearance and function desired by the majority of our customers. With our own in-house product development team, we have possibly the shortest turn-around time for providing air conditioning systems for new machines to the market.

We believe in an on-going process of product development and a commitment to continuous improvement. This is evident in all our systems as we design them with the end user, service technician and installer in mind. All of our systems are developed from our own field installations and include all components required. Whenever possible we pre-assemble as much of the system as possible and test them prior to shipping from our facilities.

IMPORTANT INFORMATION REQUIRED WHEN INQUIRING:

- Make and Model
- Serial Number
- Does the machine have factory heat?
- What model of cab? Is it factory or aftermarket?
- Engine make and model

AMMANN	60XT	325L	262B
AP240 Roller	70XT	330L	262C
AV-85 Roller	75XT	345B-2	Wheel Dozer
ASV	85XT	E120B	816B
PT60 Skidsteer	SR160	M318	825G
RC60 Skidsteer	Tractor	M322D	826C
RT40 Skidsteer	1070/970	Forklift	Wheel Loader
BOBCAT	Wheel Loader	P8000	902
S130 Skidsteer	521D TIER II	Grapple Skidder	906
X337 Excavator	570 LXT	525	908
BOMAG	570 MXT	Telehandler	943
BW213PDH-40 Roller	621B	TH360B	953
BUHLER	621C	TH103	963
B56 Wheel Loader	621D TIER II	Track Dozer	904B
CASE	621E	D3C III	908H
Backhoe	721	D3C/933 RAD	908H-2
580K/SUPER K	721B	D4H	918B
580L/580SUPER	721C	D5H	924G
580L/SUPER II	821B	D5M	928G II
580M	821C	D6D	936F
580M-2	CATERPILLAR	D6H	938F
580M-3	Articulated Rock Truck	D6M	950E
580N	D250-E	D6R	950F
Crawler	D350E ROCK	D7G	950FII
1150G	Backhoe	D7H	950G
1150H	416C	D7R	950G TIER II
850H	416D TIER II	D8L	953B
Excavator	420D	D8N	953C
9010	420D TIER II	D8N	962G
9010B	430E	D8R	963B
9020	Compactor	D9L	963C
9020B	563C	Rock Truck	966D
9030	563D	769C	966FII
9030B	Excavator	769D	966G
9040B	235	773B	966G II
CX36B	245	773D	980C
Forklift	302.5	777	980G
588G	302.7D	777B/C	988B
588G Tier III	303CR	777D ROCK	IT14B
588H	304.5	Scraper	IT14F/914F
Skidsteer	305CR	615C	IT14G/914G II
221/321D	307B	621E/623E	IT18FII/918FI
321D	311/312	621F	IT24FII/924FI
410	315	627F	IT28FII/928FI
420CT	315B	637D	IT28G/928G
430	315L	Scraper	IT38G/938G
435	320B	226	CHAMPION
465	322B	246	CHAMPION 24V Grader
		257B	

PC75R
PC75-UU3
PC95-1
PW170ES

Grader

GD555

Skidsteer

SK820-5

Track Dozer

D155
D38E
D38E-1
D39PX-21
D65E-8
D65-EX12

Wheel Loader

WA120-3
WA150L-5
WA180-3
WA200/250 LC5
WA250-1
WA250-3
WA250-3
WA300-3
WA320-3
WA350-1
WA-380-1
WA380-3
WA420-1
WA420-3
WA450-3
WA500-1
WA600
WA95

KUBOTA
Excavator

KX121-3SS
KX161-3
KX91-3
Tractor
R420
R520

LIEBHERR
Excavator

308
902
932
942
954

LINDE
E35PL Electric Forklift

LINK BELT
Excavator

3400Q
4300Q
5800

MANITOU
MT625H Telehandler

MERCEDES
MERCEDES METRIS REAR
TIE-IN

NEW HOLLAND
Backhoe

B90B
B95
B95C
LB115
LB75B
LB90

Grader

RG80

Skidsteer

LS150
LS170

Track Dozer

DC100

Tractor

TM75D

SAKAI
SV505D Roller

SENEBOGEN
830 Excavator

TEREX
Backhoe

760B TIER III
760B

Excavator

3.7

HR14/16
HR18
HR20
HR32

HR32 TIER II
HR32 TIER II
HR42
TC125 TIER III
TC125

TC29/35 TIER III
TC29/35
TC48
TC50
TC50-3
TC60 TIER III
TC75 TIER III

Material Handler

MHL 331 > 530
MHL 331
MHL 340
MHL 350A
MHL 380-2
MHL 460
MHL 320
MHL 360

Rock Truck

SKL 853

Skidsteer

PT60 TIER IV
PT80
RO70T

Telehandler

TL100 TIER III
TL100
TL120 TIER III
TL120

Wheel Loader

TL65 TIER III
TL80 TIER III
TL80 TIER III
TL80

Skidsteer

760
SKL 863
SKL 873
SKL823/33/633
SKL824/34
SKL854
SKL873 >275

THOMAS
Skidsteer

175/205
205
245/255

UNIVERSAL

1033 Tractor

VOLVO
Excavator

ECR28

Grader

G740B
G960B

Rock Truck

A25C
A35C/A40

Roller

SD70D

Skidsteer

MC110B
MC70B
MC80B
MC90B

Wheel Loader

L120
L120C
L120E
L150C
L20B
L70
L70C
L90
L90B
L90D
L90E

WACKER

WL60 Wheel Loader

YANMAR

VIO35-6A Excavator

ZETOR

10540 CDN
10540 US
11641 US
12045
6340
6341 CDN
6341 US
7340
7341

7341 TURBO CDN
9540 CDN
9540 US
9641 CDN
9641 US
URI DUAL EVAPORATOR
URII TWIN



ROOF/NOSE MOUNTED REFRIGERATION UNITS



With over 25 years of experience, Advanced Temperature Control (ATC) a division of Arctic Traveler Canada, has specialized in the engineering and manufacture of direct drive mobile refrigeration and heating systems for safe delivery of temperature sensitive products. Our line of Truck Refrigeration products has been continuously updated and improved to meet the requirements of today's competitive markets.

With an extensive dealer network providing coverage throughout North America, Guam, Hawaii and Puerto Rico which offers both installation and on-going service

support. ATC welcomes inquiries to modify or customize specialty units for any unique application. Inquiries for installations outside of North America are handled by our corporate headquarters and can be custom manufactured to local specifications.

Advanced Temperature Control is a proud member of the exclusive Mercedes Benz Master Upfitter program, producing solutions for Refrigerated Sprinter and Metris that consistently meet the high-quality standards expected from Mercedes-Benz.

ADVANCED TEMPERATURE CONTROL

1416 Graham's Lane
Burlington, Ontario Canada,
L7S 1W3

Tel: (833) 878-5282

Fax: (905) 637-3363

Email: sales@atc.ca

COMMON AC TOOLS AVAILABLE TO ORDER

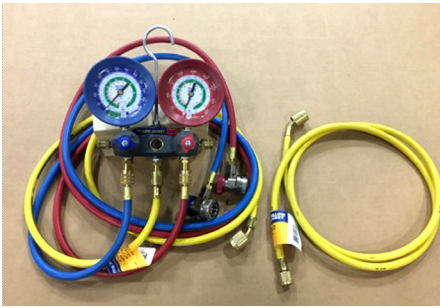

Gauge Set

8-12-0016

- Aluminum R134a/R12 Gauge Set
- 72" Hose
- 72" Yellow Charging Hose
- Premium R134a Couplers
- Rubber Gauge Protectors
- Custom molded carrying case



Vacuum Pump

18-20-VP6D

- A highly efficient two-stage rotary vane oil-sealed pump field rated @ 10 microns or better
- 1/4" and 1/2" Male Flare (1/4" to 1/2" Acme Fittings available (16-19-2000)
- 6.0 CFM
- 13" L x 5.5" W x 10" H
- 22.5 Lbs



Electric Scale

18-60-0110

- Weigh in charge direct from tank to system
- 110lb capacity
- Includes: Charging module, power pack, instruction manual and carrying case
- 15.5" x 12.25" x 3.25"
- 9 Lbs.



Recovery

18-40-1000

- Compact & Lightweight
- Twin cylinders and twin condensors for ultra fast recovery
- Refrigerant-Isolated Crankcase, eliminating bearing contamination
- Recyclable Reclaimer tanks - Sold Separately
- 24 Lbs



Sniffer

18-30-1002

- Electronic leak detector features a long life solid electrolyte sensor technology that is designed to detect the more current and difficult HFC refrigerants such as R-134a in addition to all HCFC and CFC refrigerants including hydrocarbon "blends".
- 3 Adjustable sensitivity levels.
- Visual LED Lead alarm located near sensor

COMMON AC TOOLS AVAILABLE TO ORDER



Valve Core Kit

18-11-2101

- Replace Valve Core Without Losing System Charge! Works With R12 & R134a Systems
- Valve body tool and (5) configuration set-ups, from standard size to large bore valve cores
- Plastic Carrying Case



Flush Kit

18-11-1040

- Easy-to-use system removes refrigerant oil, moisture and contaminants from system components and lines during retrofitting and compressor replacement
- Kit Includes: rubber tip flush gun, canister with adapter & Hose
- Use with flushing agent and pressurize with shop air



Valve Core Kit

18-60-2100

- Valve Core Repair Kit includes: Standard Valve Cores
- Large Bore Valve Cores
- High Flow Valve Core
- Valve Core Remover



O-Ring Kit

16-60-9000

- High and Low Side Service Caps
- #6, 8 and 10 O-Ring To Flare Adapters
- 100 ea #6, 8 and 10 O-Rings

A/C SYSTEMS CONFIGURATION WORKSHEET

(photocopy this sheet, **fill out all information** and **email us**)

This worksheet will assist us in determining exactly what A/C components are required for your specific vehicle.

Vehicle Make _____ **Model** _____ **Year** _____

Engine Type* _____ **Eng Series** _____ **Voltage** _____

What type of AC system do you want? Check one below (note: all types shown may not be available for your specific vehicle.)

Roof Mount Unit _____ **Wall/Between-Seat Unit** _____ **In-Dash Unit** _____

Ceiling/Headliner Unit _____ **Self-Contained**** _____ **Hydraulic** _____

**self contained is defined as an off-road AC Unit operated by a compressor that is not attached to or driven by the vehicle's engine.

Please tell us who you are by filling out all the information below. We will return your request with a detailed listing of all necessary components required for a complete AC installation.

Name _____

Phone No _____ **Fax No.** _____ **Date** _____

Email To:

sales@visionaire-inc.com

atcparts@atc.ca

sales@hammond.com



www.visionaire-inc.com
866-838-2810



<https://atc.ca>
800-295-4156



www.hammondac.com
800-267-2665

DISTRIBUTED BY:



AGRICULTURE

FORESTRY

HEAVY EQUIPMENT

MARINE

MINING